

# FCU-20.O

## FCU-20

- Operating Instructions
- Control unit





# Safety rules

## DANGER!



“**DANGER!**” indicates an imminently hazardous situation which, if not avoided, will result in death or serious injury. This signal word is to be limited to the most extreme situations. This signal word is not used for property damage hazards unless personal injury risk appropriate to this level is also involved.

## WARNING!



“**WARNING!**” indicates a potentially hazardous situation which, if not avoided, could result in death or serious injury. This signal word is not used for property damage hazards unless personal injury risk appropriate to this level is also involved.

## CAUTION!



“**CAUTION!**” indicates a potentially hazardous situation which, if not avoided, may result in minor or moderate injury. It may also be used to alert against unsafe practices that may cause property damage.

## NOTE!



“**NOTE!**” indicates a situation which implies a risk of impaired welding result and damage to the equipment.

## Important!

“**Important!**” indicates practical hints and other useful special-information. It is no signal word for a harmful or dangerous situation.

Whenever you see any of the symbols shown above, you must pay even closer attention to the contents of the manual!

## General remarks



This equipment has been made in accordance with the state of the art and all recognised safety rules. Nevertheless, incorrect operation or misuse may still lead to danger for

- the life and well-being of the operator or of third parties,
- the equipment and other tangible assets belonging to the owner/operator,
- efficient working with the equipment.

All persons involved in any way with starting up, operating, servicing and maintaining the equipment must

- be suitably qualified
- know about welding and
- read and follow exactly the instructions given in this manual.

The instruction manual must be kept at the machine location at all times. In addition to the instruction manual, copies of both the generally applicable and the local accident prevention and environmental protection rules must be kept on hand, and of course observed in practice.

All the safety instructions and danger warnings on the machine itself:

- must be kept in a legible condition
- must not be damaged, must not be removed
- must not be covered, pasted or painted over

For information about where the safety instructions and danger warnings are located on the machine, please see the section of your machine’s instruction manual headed “General remarks”.

**General remarks**  
(continued)

Any malfunctions which might impair machine safety must be eliminated immediately - meaning before the equipment is next switched on.

**It's your safety that's at stake!**

**Utilisation for intended purpose only**



The machine may only be used for jobs as defined by the "Intended purpose".

The machine may ONLY be used for the welding processes stated on the rating plate.

Utilisation for any other purpose, or in any other manner, shall be deemed to be "not in accordance with the intended purpose". The manufacturer shall not be liable for any damage resulting from such improper use.

Utilisation in accordance with the "intended purpose" also comprises

- complete reading and following of all the instructions given in this manual
- complete reading and following of all the safety instructions and danger warnings
- performing all stipulated inspection and servicing work.

The appliance must never be used for the following:

- Thawing pipes
- Charging batteries/accumulators
- Starting engines

The machine is designed to be used in industrial and workshop environments. The manufacturer shall not be liable for any damage resulting from use of the machine in residential premises.

likewise the manufacturer will accept no liability for defective or faulty work results.

**Ambient conditions**



Operation or storage of the power source outside the stipulated range is deemed to be "not in accordance with the intended use". The manufacturer shall not be liable for any damage resulting herefrom.

Temperature range of ambient air:

- when operating: - 10 °C to + 40 °C (14 °F to 104 °F)
- when being transported or stored: - 25 °C to + 55 °C (-13 °F to 131 °F)

Relative atmospheric humidity:

- up to 50 % at 40 °C (104 °F)
- up to 90 % at 20 °C (68 °F)

Ambient air: Free of dust, acids, corrosive gases or substances etc.

Elevation above sea level: Up to 2000 m (6500 ft)

**Obligations of owner/operator**



The owner/operator undertakes to ensure that the only persons allowed to work with the machine are persons who

- are familiar with the basic regulations on workplace safety and accident prevention and who have been instructed in how to operate the machine
- have read and understood the sections on "safety rules" and the "warnings" contained in this manual, and have confirmed as much with their signatures
- be trained in such a way that meets with the requirements of the work results

Regular checks must be performed to ensure that personnel are still working in a safety-conscious manner.

## Obligations of personnel

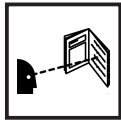

Before starting work, all persons to be entrusted with carrying out work with (or on) the machine shall undertake

- to observe the basic regulations on workplace safety and accident prevention
- to read the sections on “safety rules” and the “warnings” contained in this manual, and to sign to confirm that they have understood these and will comply with them.

Before leaving the workplace, personnel must ensure that there is no risk of injury or damage being caused during their absence.

## Mains connection

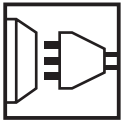

High-performance devices can affect the quality of the mains power due to their current-input.

This may affect a number of types of device in terms of:

- connection restrictions
- criteria with regard to maximum permissible mains impedance <sup>\*)</sup>
- criteria with regard to minimum short-circuit power requirement <sup>\*)</sup>

<sup>\*)</sup> at the interface with the public mains network

see Technical Data

In this case, the plant operator or the person using the device should check whether or not the device is allowed to be connected, where appropriate through discussion with the power supply company.

## Protection for yourself and other persons



When welding, you are exposed to many different hazards such as:

- flying sparks and hot metal particles
- arc radiation which could damage your eyes and skin



- harmful electromagnetic fields which may put the lives of cardiac pace-maker users at risk



- electrical hazards from mains and welding current



- increased exposure to noise



- noxious welding fumes and gases.

Anybody working on the workpiece during welding must wear suitable protective clothing with the following characteristics:

- flame-retardant
- isolating and dry
- must cover whole body, be undamaged and in good condition
- protective helmet
- trousers with no turn-ups



**Protection for yourself and other persons**  
(continued)



“Protective clothing” also includes:

- protecting your eyes and face from UV rays, heat and flying sparks with an appropriate safety shield containing appropriate regulation filter glass
- wearing a pair of appropriate regulation goggles (with sideguards) behind the safety shield
- wearing stout footwear that will also insulate even in wet conditions
- protecting your hands by wearing appropriate gloves (electrically insulating, heat-proof)
- To lessen your exposure to noise and to protect your hearing against injury, wear ear-protectors!



Keep other people - especially children - well away from the equipment and the welding operation while this is in progress. If there are still any other persons nearby during welding, you must

- draw their attention to all the dangers (risk of being dazzled by the arc or injured by flying sparks, harmful welding fumes, high noise immission levels, possible hazards from mains or welding current ...)
- provide them with suitable protective equipment and/or
- erect suitable protective partitions or curtains.

**Information on noise emission values**



The device generates a maximum sound power level of <80 dB(A) (ref. 1pW) when idling and in the cooling phase following operation at the maximum permissible operating point under maximum rated load conditions according to EN 60974-1.

It is not possible to provide a workplace-related emission value during welding (or cutting) as this is influenced by both the process and the environment. All manner of different welding parameters come into play, including the welding process (MIG/MAG, TIG welding), the type of power selected (DC or AC), the power range, the type of weld metal, the resonance characteristics of the workpiece, the workplace environment, etc.

**Hazards from noxious gases and vapours**



The fumes given off during welding contain gases and vapors that are harmful to health.

Welding fumes contain substances which may cause birth defects and cancers.

Keep your head away from discharges of welding fumes and gases.

Do not inhale any fumes or noxious gases that are given off.  
Extract all fumes and gases away from the workplace, using suitable means.

Ensure a sufficient supply of fresh air.

Where insufficient ventilation is available, use a respirator mask with an independent air supply.

If you are not sure whether your fume-extraction system is sufficiently powerful, compare the measured pollutant emission values with the permitted threshold limit values.

**Hazards from  
noxious gases  
and vapours**  
(continued)

The harmfulness of the welding fumes will depend on e.g. the following components:

- the metals used in and for the workpiece
- the electrodes
- coatings
- cleaning and degreasing agents and the like

For this reason, pay attention to the relevant Materials Safety Data Sheets and the information given by the manufacturer regarding the components listed above.

Keep all flammable vapors (e.g. from solvents) well away from the arc radiation.

**Hazards from  
flying sparks**



Flying sparks can cause fires and explosions!

Never perform welding anywhere near combustible materials.

Combustible materials must be at least 11 meters (35 feet) away from the arc, or else must be covered over with approved coverings.

Have a suitable, approved fire extinguisher at the ready.

Sparks and hot metal particles may also get into surrounding areas through small cracks and openings. Take suitable measures here to ensure that there is no risk of injury or fire.

Do not perform welding in locations that are at risk from fire and/or explosion, or in enclosed tanks, barrels or pipes, unless these latter have been prepared for welding in accordance with the relevant national and international standards.

Welding must NEVER be performed on containers that have had gases, fuels, mineral oils etc. stored in them. Even small traces of these substances left in the containers are a major explosion hazard.

**Hazards from  
mains and weld-  
ing current**



An electric shock is potentially life-threatening, and can be fatal.

Do not touch any live parts, either inside or outside the machine.



In MIG/MAG and TIG welding, the welding wire, the wire spool, the drive rollers and all metal parts having contact with the welding wire are also live.

Always place the wirefeeder on an adequately insulated floor or base, or else use a suitable insulating wirefeeder holder.

Ensure sufficient protection for yourself and for other people by means of a dry base or cover that provides adequate insulation against the ground/frame potential. The base or cover must completely cover the entire area between your body and the ground/frame potential.

All cables and other leads must be firmly attached, undamaged, properly insulated and adequately dimensioned. Immediately replace any loose connections, scorched, damaged or underdimensioned cables or other leads.



## Hazards from mains and welding current

(continued)

Do not loop any cables or other leads around your body or any part of your body.

Never immerse the welding electrode (rod electrode, tungsten electrode, welding wire, ...) in liquid in order to cool it, and never touch it when the power source is ON.

Twice the open-circuit voltage of one single welding machine may occur between the welding electrodes of two welding machines. Touching the potentials of both electrodes simultaneously may be fatal.

Have the mains and the machine supply leads checked regularly by a qualified electrician to ensure that the PE (protective earth) conductor is functioning correctly.

Only run the machine on a mains network with a PE conductor, and plugged into a power outlet socket with a protective-conductor contact.

If the machine is run on a mains network without a PE conductor and plugged into a power outlet socket without a protective-conductor contact, this counts as gross negligence and the manufacturer shall not be liable for any resulting damage.

Wherever necessary, use suitable measures to ensure that the workpiece is sufficiently grounded (earthed).

Switch off any appliances that are not in use.

Wear a safety harness if working at height.

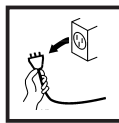

Before doing any work on the machine, switch it off and unplug it from the mains.

Put up a clearly legible and easy-to-understand warning sign to stop anybody inadvertently plugging the machine back into the mains and switching it back on again.

After opening up the machine:

- discharge any components that may be storing an electrical charge
- ensure that all machine components are electrically dead.

If work needs to be performed on any live parts, there must be a second person on hand to immediately switch off the machine at the main switch in an emergency.

## Stray welding currents



If the following instructions are ignored, stray welding currents may occur. These can cause:

- fires
- overheating of components that are connected to the workpiece
- destruction of PE conductors
- damage to the machine and other electrical equipment

Ensure that the workpiece clamp is tightly connected to the workpiece.

Attach the workpiece clamp as close as possible to the area to be welded.

On electrically conductive floors, the machine must be set up in such a way that it is sufficiently insulated from the floor.



## Stray welding currents (continued)

When using current supply distributors, twin head wire feeder fixtures etc., please note the following: The electrode on the unused welding torch/welding tongs is also current carrying. Please ensure that there is sufficient insulating storage for the unused welding torch/tongs.

In the case of automated MIG/MAG applications, ensure that only insulated filler wire is routed from the welding wire drum, large wirefeeder spool or wire spool to the wirefeeder.

## EMC device classifications



Devices with emission class A:

- are only designed for use in an industrial setting
- can cause conducted and emitted interference in other areas.

Devices with emission class B:

- satisfy the emissions criteria for residential and industrial areas. This also applies to residential areas in which power is supplied from the public low-voltage grid.

EMC device classification as per the rating plate or technical specifications

## EMC measures



In certain cases, even though a device complies with the standard limit values for emissions, it may affect the application area for which it was designed (e.g. when there is sensitive equipment at the same location, or if the site where the device is installed is close to either radio or television receivers).

If this is the case, then the operator is obliged to take appropriate action to rectify the situation.

Examine and evaluate any possible electromagnetic problems that may occur on equipment in the vicinity, and the degree of immunity of this equipment, in accordance with national and international regulations:

- safety features
- mains, signal and data-transmission leads
- IT and telecoms equipment
- measurement and calibration devices

Ancillary measures for preventing EMC problems:

### a) Mains supply

- If electromagnetic interference still occurs, despite the fact that the mains connection is in accordance with the regulations, take additional measures (e.g. use a suitable mains filter).

### b) Welding cables

- Keep these as short as possible
- Arrange them so that they run close together (to prevent EMI problems as well)
- Lay them well away from other leads.

### c) Equipotential bonding

### d) Workpiece grounding (earthing)

- where necessary, run the connection to ground (earth) via suitable capacitors.

### e) Shielding, where necessary

- Shield other equipment in the vicinity
- Shield the entire welding installation.



## EMI Precautions



Electromagnetic fields may cause as yet unknown damage to health.

- Effects on the health of persons in the vicinity, e.g. users of heart pacemakers and hearing aids
- Users of heart pacemakers must take medical advice before going anywhere near welding equipment or welding workplaces
- Keep as much space as possible between welding cables and head/body of welder for safety reasons
- Do not carry welding cables and hose pack over shoulder and do not loop around body or any part of body

## Particular danger spots



Keep your hands, hair, clothing and tools well away from all moving parts, e.g.:

- fans
- toothed wheels, rollers, shafts
- wire-spools and welding wires

Do not put your fingers anywhere near the rotating toothed wheels of the wirefeed drive.0

Covers and sideguards may only be opened or removed for as long as is absolutely necessary to carry out maintenance and repair work.

While the machine is in use:

- ensure that all the covers are closed and that all the sideguards are properly mounted ...
- ... and that all covers and sideguards are kept closed.



When the welding wire emerges from the torch, there is a high risk of injury (the wire may pierce the welder's hand, injure his face and eyes ...). For this reason, when feeder-inching etc., always hold the torch so that it is pointing away from your body (machines with wirefeeder).



Do not touch the workpiece during and after welding - risk of injury from burning!

Slag may suddenly "jump" off workpieces as they cool. For this reason, continue to wear the regulation protective gear, and to ensure that other persons are suitably protected, when doing post-weld finishing on workpieces.

Allow welding torches - and other items of equipment that are used at high operating temperatures - to cool down before doing any work on them.



Special regulations apply to rooms at risk from fire and/or explosion. Observe all relevant national and international regulations.



Power sources for use in spaces with increased electrical danger (e.g. boilers) must be identified by the  (for "safety") mark. However, the power source should not be in such rooms.



Risk of scalding from accidental discharge of hot coolant. Before unplugging the connectors for coolant forward flow and return flow, switch off the cooling unit.

**Particular danger spots**  
(continued)



When hoisting the machines by crane, only use suitable manufacturer-supplied lifting devices.

- Attach the chains and/or ropes to **all** the hoisting points provided on the suitable lifting device.
- The chains and/or ropes must be at an angle which is as close to the vertical as possible.
- Remove the gas cylinder and the wirefeed unit (from MIG/MAG and TIG units).

When hoisting the wirefeed unit by crane during welding, always use a suitable, insulating suspension arrangement (MIG/MAG and TIG units).

If a machine is fitted with a carrying strap or carrying handle, remember that this strap is **ONLY** to be used for lifting and carrying the machine by hand. The carrying strap is **NOT** suitable for transporting the machine by crane, fork-lift truck or by any other mechanical hoisting device.



Danger of colourless and odourless inert gas escaping unnoticed, when using an adapter for the inert gas protection. Seal the adapter thread for the inert gas connection using Teflon tape before assembly.

**Danger from shielding-gas cylinders**



Shielding-gas cylinders contain pressurized gas and may explode if they are damaged. As shielding-gas cylinders are an integral part of the overall welding outfit, they also have to be treated with great care.

Protect shielding-gas cylinders containing compressed gas from excessive heat, mechanical impact, slag, naked flames, sparks and arcs.

Mount the shielding-gas cylinders in the vertical and fasten them in such a way that they cannot fall over (i.e. as shown in the instruction manual).

Keep shielding-gas cylinders well away from welding circuits (and, indeed, from any other electrical circuits).

Never hang a welding torch on a shielding-gas cylinder.

Never touch a shielding-gas cylinder with a welding electrode.

Explosion hazard - never perform welding on a pressurized shielding-gas cylinder.

Use only shielding-gas cylinders that are suitable for the application in question, together with matching, suitable accessories (pressure regulators, hoses and fittings, ...). Only use shielding-gas cylinders and accessories that are in good condition.

When opening the valve of a shielding-gas cylinder, always turn your face away from the outlet nozzle.

Close the shielding-gas cylinder valve when no welding is being carried out.

When the shielding-gas cylinder is not connected up, leave the cap in place on the shielding-gas cylinder valve.

Observe the manufacturer's instructions and all relevant national and international rules applying to shielding-gas cylinders and accessories.



## Safety precautions at the installation site and when being transported

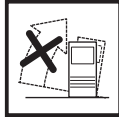

A machine that topples over can easily kill someone! For this reason, always place the machine on an even, firm floor in such a way that it stands firmly.

- An angle of inclination of up to 10° is permissible.



Special regulations apply to rooms at risk from fire and/or explosion. Observe all relevant national and international regulations.

By means of internal instructions and checks, ensure that the workplace and the area around it are always kept clean and tidy.

The appliance must only be installed and operated in accordance with the protection type stated on the specifications plate.

When installing the appliance, please ensure a clearance radius of 0.5 m (1.6ft.) , so that cool air can circulate freely.

When transporting the appliance, please ensure that the valid national and regional guidelines and accident protection regulations are followed. This applies in particular to guidelines in respect of dangers during transportation and carriage.

Before transportation, completely drain any coolant and dismantle the following components:

- Wire feed
- Wire wound coil
- Gas bottle

Before commissioning and after transportation, a visual check for damage must be carried out. Any damage must be repaired by trained service personnel before commissioning.

## Safety precautions in normal operation



Only operate the machine if all of its protective features are fully functional. If any of the protective features are not fully functional, this endangers:

- the life and well-being of the operator or other persons
- the equipment and other tangible assets belonging to the owner/operator
- efficient working with the equipment.

Any safety features that are not fully functional must be put right before you switch on the machine.

Never evade safety features and never put safety features out of order.

Before switching on the machine, ensure that nobody can be endangered by your doing so.

- At least once a week, check the machine for any damage that may be visible from the outside, and check that the safety features all function correctly.
- Always fasten the shielding-gas cylinder firmly, and remove it altogether before hoisting the machine by crane.
- Owing to its special properties (in terms of electrical conductivity, frost-proofing, materials-compatibility, combustibility etc.), only original coolant of the manufacturer is suitable for use in our machines.
- Only use suitable original coolant of the manufacturer.
- Do not mix original coolant of the manufacturer with other coolants.

## Safety precautions in normal operation

(continued)

- If any damage occurs in cases where other coolants have been used, the manufacturer shall not be liable for any such damage, and all warranty claims shall be null and void.
- Under certain conditions, the coolant is flammable. Only transport the coolant in closed original containers, and keep it away from sources of ignition.
- Used coolant must be disposed of properly in accordance with the relevant national and international regulations. A safety data sheet is available from your service centre and on the manufacturer's homepage.
- Before starting welding - while the machine is still cool - check the coolant level.



## Preventive and corrective maintenance



With parts sourced from other suppliers, there is no certainty that these parts will have been designed and manufactured to cope with the stressing and safety requirements that will be made of them. Use only original spares and wearing parts (this also applies to standard parts).

Do not make any alterations, installations or modifications to the machine without getting permission from the manufacturer first.

Replace immediately any components that are not in perfect condition.

When ordering spare parts, please state the exact designation and the relevant part number, as given in the spare parts list. Please also quote the serial number of your machine.

## Safety inspection



The owner/operator is obliged to have a safety inspection performed on the machine at least once every 12 months.

The manufacturer also recommend the same (12-month) interval for regular calibration of power sources.

A safety inspection, by a trained and certified electrician, is prescribed:

- after any alterations
- after any modifications or installations of additional components
- following repairs, care and maintenance
- at least every twelve months.

Observe the relevant national and international standards and directives in connection with the safety inspection.

More detailed information on safety inspections and calibration is available from your regional or national service centre, who will be pleased to provide you with copies of the necessary documents upon request.

## Disposal



Do not dispose of this device with normal domestic waste!

To comply with the European Directive 2002/96/EC on Waste Electrical and Electronic Equipment and its implementation as national law, electrical equipment that has reached the end of its life must be collected separately and returned to an approved recycling facility. Any device that you no longer require must be returned to our agent, or find out about the approved collection and recycling facilities in your area.

Ignoring this European Directive may have potentially adverse effects on the environment and your health!

## Safety markings



Equipment with CE-markings fulfils the basic requirements of the Low-Voltage and Electromagnetic Compatibility Guideline (e.g. relevant product standards according to EN 60 974). .



Equipment marked with the CSA-Test Mark fulfils the requirements made in the relevant standards for Canada and the USA.

## Data security

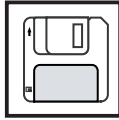

The user is responsible for the data security of changes made to factory settings. The manufacturer is not liable, if personal settings are deleted.

## Copyright



Copyright to this instruction manual remains the property of the manufacturer.

The text and illustrations are all technically correct at the time of going to print. The right to effect modifications is reserved. The contents of the instruction manual shall not provide the basis for any claims whatever on the part of the purchaser. If you have any suggestions for improvement, or can point out to us any mistakes which you may have found in the manual, we should be most grateful for your comments.

# Table of contents

<b>General</b> .....	<b>5</b>
Device concept.....	5
Field of application FCU 20 .....	5
Field of application FCU 20.O .....	5
<b>Control elements</b> .....	<b>6</b>
Control elements .....	6
Control panel.....	6
Rear view .....	7
<b>Touchscreen display</b> .....	<b>9</b>
Touchscreen display.....	9
Tips for use.....	9
<b>Parameter entry options</b> .....	<b>10</b>
General.....	10
Multifunction wheel.....	10
Numerical pad .....	10
<b>Menu navigation</b> .....	<b>11</b>
Navigating through process parameter pages .....	11
Touch buttons.....	11
Multifunction wheel.....	11
<b>List of parameters</b> .....	<b>12</b>
Process parameters .....	12
<b>Description of process parameters</b> .....	<b>13</b>
General.....	13
Parameter page 1 .....	13
Parameter page 2 .....	14
Parameter page 3 .....	15
Parameter page 4 .....	16
Parameter page 5 .....	17
Parameter page 6 .....	18
Parameter page 7 .....	19
Parameter page - pneumatic test.....	19
<b>Parameter calibration</b> .....	<b>20</b>
General.....	20
Procedure.....	20
<b>Program management</b> .....	<b>21</b>
General.....	21
Saving welding programs .....	21
Loading welding programs .....	22
<b>Segment mode</b> .....	<b>23</b>
General.....	23
Segment ON mode .....	23
Segment OFF mode.....	24
<b>Description of pedal remote control</b> .....	<b>24</b>
FRC-1.....	24
<b>Service parameters</b> .....	<b>25</b>
General.....	25
Navigation .....	25
Calling up service parameters.....	25
Parameter page 1 - PLC inputs and outputs.....	25
PLC list of inputs and outputs .....	26
Parameter page 2 - Language selection .....	26
Parameter page 3 - Power source .....	27
Parameter page 4 - Calibration .....	28
Parameter page 5 - Hardware.....	28

Decommissioning .....	29
Data table FCU-20 .....	29
Data table FCU-20.O .....	29
Calculating the MFaktor .....	29
<b>Troubleshooting .....</b>	<b>30</b>
Safety .....	30
General.....	30
Troubleshooting.....	30
Error messages .....	30
<b>Technical data.....</b>	<b>32</b>
FCU-20 technical data .....	32
Rating plate FCU-20 / 20.O.....	32
<b>Spare parts list FCU-20.....</b>	<b>33</b>
FCU-20 spare parts list .....	33
<b>Accessories and options FCU-20 .....</b>	<b>35</b>
System overview .....	35
Installation kit .....	35
Pedal remote control .....	35
Connecting lead .....	35
<b>Spare parts list FCU-20.O .....</b>	<b>36</b>
FCU-20.O spare parts list.....	36
<b>Accessories and options FCU20.O.....</b>	<b>38</b>
System overview .....	38
Installation kit .....	38
Pedal remote control .....	38
Connecting lead .....	38
<b>EU Declaration of conformity FCU20 .....</b>	<b>39</b>
<b>EU Declaration of conformity FCU20.O.....</b>	<b>40</b>
<b>Circuit diagrams .....</b>	<b>41</b>



# General

## Device concept



*FCU-20 control unit*

The compact and rugged design of the FCU-20 control unit allows it to be used in a wide variety of control applications. Powder coating of all aluminium housing components. Can be used with the Fronius FTT and FRT rotation tables. The FCU-20 control unit has a touch-screen display to facilitate menu navigation and parameter entry.

## Field of application FCU 20

The FCU-20 control unit is intended exclusively for use with the Fronius FTT-10/ 40/ 150/ 300 and FRT-50/ 150 rotation tables.

It can be used in the following welding processes:

- MIG/MAG process
- TIG process
- Plasma process

## Field of application FCU 20.O

The FCU-20.O control unit is intended exclusively for use with the Fronius FTT-380 - 70000 and FRT 1000 - 10000 rotation tables.

It can be used in the following welding processes:

- MIG/MAG process
- TIG process
- Plasma process

# Control elements

## Control elements



**WARNING!** Operating the equipment incorrectly can cause serious injury and damage. Do not use the functions described here until you have thoroughly read and understood the following documents:

- these operating instructions
- all operating instructions for the system components

## Control panel

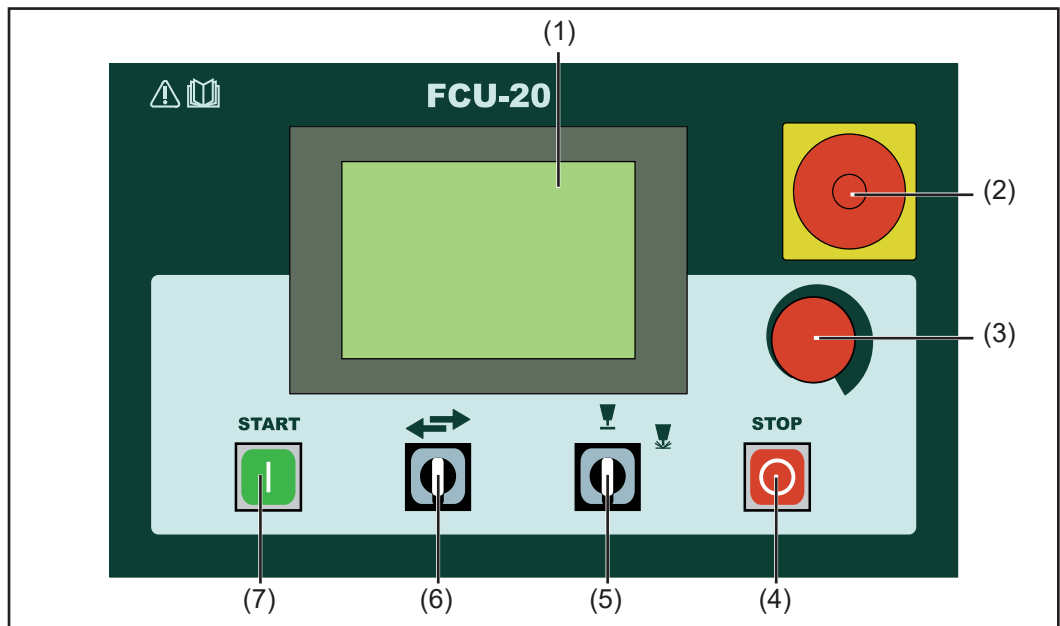

FCU-20 control panel

### (1) Touchscreen display

For menu navigation, input and editing of parameter values by touching the display. The multifunction wheel (3) can also be used to input and edit data.

### (2) Emergency Stop button

Stops all movements and prevents restarting. The power source arc is broken immediately. The "EMERGENCY STOP" message appears on the FCU-20 control panel display. All controls are disabled during an emergency stop.



**NOTE!** Before starting work, check that the Emergency Stop protection device is working correctly.

### (3) Multifunction wheel

For selecting and editing welding parameters, even during an automatic program sequence. Press the multifunction wheel once to select the highlighted parameter and then edit it.

### (4) Stop button

- Used to stop an automatic program sequence. The start button (7) cannot be used to restart the program sequence.
- Pressing this button and the start button (7) simultaneously changes the direction of rotation of the face plate.
- Pressing this button and the manual mode button (6) simultaneously activates the pneumatic unit
- Press for > 5 seconds to access the service parameter pages.

## Control panel (continued)

### (5) Welding ON/OFF selector switch

For choosing whether to run the automatic program sequence with or without welding.

**Important!** Welding can also be activated/deactivated using the "Welding ON/OFF" parameter.

### (6) Manual mode button

To move the face plate manually. Press and hold the button for more than seven seconds to change to the maximum traversing speed.

The traversing direction in manual mode is changed by modifying the "Direction" service parameter.

### (7) Start button

- Used to start an automatic program sequence.

- Pressing this button and the stop button (4) simultaneously changes the direction of rotation of the face plate.

**Important!** Please note that once the start button has been pressed, rotation will not start until the start-up delay has expired.

## Rear view

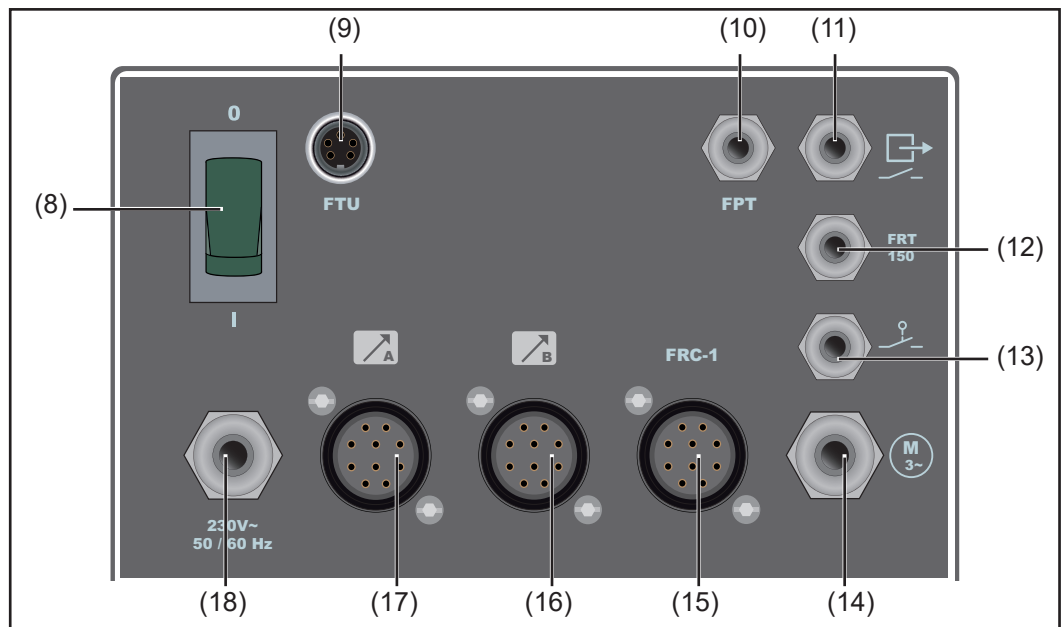

FCU-20 rear view

### (8) Mains switch

Used to switch the FCU-20 control unit on and off. The supply voltage for the connected rotation table is also switched on/off using this switch. The mains fuse (1.5 A) is in the mains switch. When the device is switched on, this switch is illuminated.

### (9) "FTU connecting plug" option

EMERGENCY STOP connection to tripod unit

### (10) Cable output for pneumatic unit

24 VDC output

### (11) Cable output to start external unit

Start release for external device

### (12) Cable output FRT 150 (FCU-20)

Control line to the rotation table (3,5 m)

### (13) Limit switch cable output

Control line to the rotation table limit switches (3.5 m).

**Rear view**  
(continued)

---

**(14) Motor cable output**

Control line to the rotation table (3.5 m).

---

**(15) "FRC-1 connecting plug" option**

Start/Stop function via remote control

---

**(16) Power source B connecting plug**

Connection to the relevant power source

---

**(17) Power source A connecting plug**

Connection to the relevant power source

---

**(18) Mains cable output**

Mains cable (5 m)

---

# Touchscreen display

## Touchscreen display

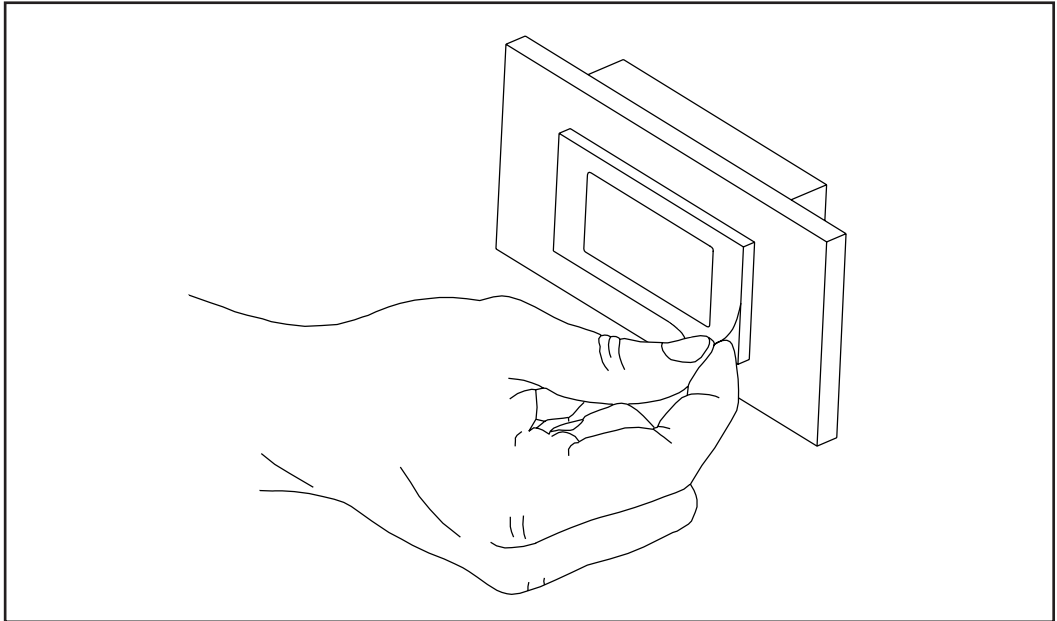

*Touchscreen display with protective film*

## Tips for use

Please note the following when using the touchscreen display.

- The touchscreen display consists of an analogue resistive layer covered by a protective film. Remove the protective film if it becomes heavily soiled and attach a new one.  
The item number of the film can be found in the FCU-20 spare parts list.

**Important!** Fronius accepts no liability for damage arising from working without a protective film. This also applies if the damage occurs during the device's guarantee period.

- To use the touchscreen display, gently press the relevant button on the display with your finger.
- Do not touch more than one part of the display at a time.
- Do not touch the display with sharp objects.
- Avoid excessively humid environments - the touchscreen display should not come into contact with water.
- Avoid using in situations where the touchscreen display may be exposed to direct sunlight or condensation.
- Avoid using in places where flammable or corrosive gases, or airborne pollutants such as dust, iron filings or oil smoke are present.
- Avoid using in places where the device may be exposed to biological solvents (thinner, benzene) or strong alkaline substances (alkalis, caustic soda).

# Parameter entry options

## General

Some parameters can be amended during an automatic program sequence. The amended values are applied immediately, but are not saved in the currently loaded program.

## Multifunction wheel

To use the multifunction wheel, proceed as follows:

1. Move the cursor (black rectangle) to the parameter that you wish to change by turning the multifunction wheel.
2. Press the multifunction wheel once to enable the parameter for editing - the black rectangle now flashes.
3. Turn the multifunction wheel clockwise to increase the value. Turn anti-clockwise to decrease the value.
4. Press the multifunction wheel again to block parameter entry.

## Numerical pad

To use the numerical pad, proceed as follows:

1. Press the parameter value that is to be changed. The numerical pad then opens.
2. Enter the value by touching the relevant number keys.
3. Confirm input value by pressing Enter. The numerical pad closes automatically.

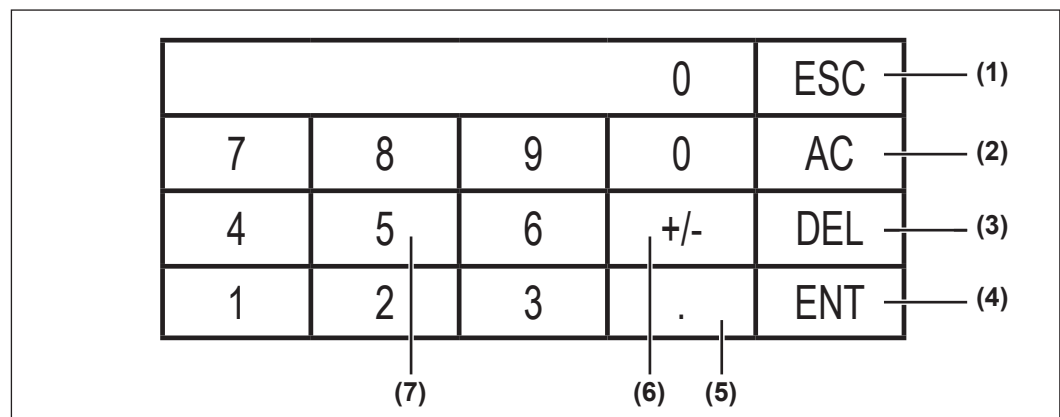

---

**(1) ESC button**

To quit the numerical pad.

---

**(2) AC button**

To delete the whole value.

---

**(3) DEL button**

To delete one decimal place, i.e. move the cursor back one space.

---

**(4) Enter button**

To apply the entered value. Once applied, the numerical pad closes automatically.

---

**(5) Decimal button**

To enter a decimal point.

---

**(6) + / - button**

To change the sign.

---

**(7) Numeric buttons**

To enter the required value.



---

# Menu navigation

## Navigating through process parameter pages

On the process parameter pages, the user can scroll back and forth using the following controls:

### Touch buttons

	- Scroll to the next page
	- Scroll to the previous page
	- Escape to main menu (parameter page 1)

### Multifunction wheel

Line change:

- Next parameter line = turn 3 steps clockwise
- Previous parameter line = turn 3 steps anti-clockwise

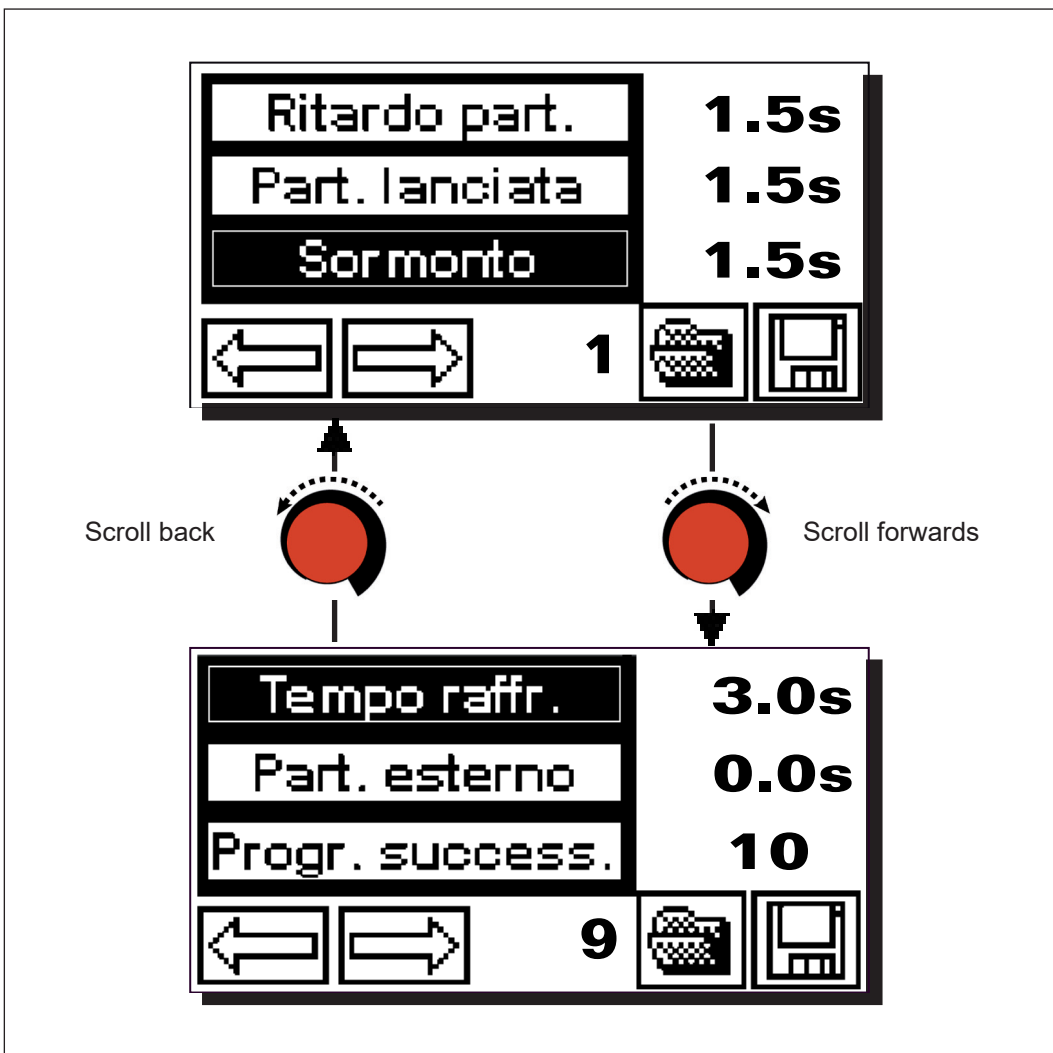

# List of parameters

## Process parameters

Parameter designation	Setting range
Direction << >>	Clockwise rotation, anti-clockwise rotation
Rotation speed	rpm (depends on rotation table)
Welding	ON / OFF
Operation	2-step
Job	0-3
Downslope	0.0 - 60.0 s
Crater-filling	0.0 - 60.0 s
Start-up delay	0.0 - 60.0 s
Flying Start	0.0 - 60.0 s
Overlapping	0.0 - 60.0 s
Cooling time	0.1 - 60.0 s
External start	0.0 - 99.00 s
Successor program	0 - 99
Return travel	ON / OFF
Pneumatic	ON / OFF
Segment	ON / OFF
Power source A (2 power sources option)	ON / OFF
Power source B (2 power sources option)	ON / OFF
Pneumatic - UP	No status indicators
Pneumatic - DOWN	No status indicators



# Description of process parameters

## General

A whole range of parameters must be coordinated to ensure that the various components in the power source and control unit work together properly. These parameters are referred to as process parameters, and contain mainly information for the fine-tuning of the components (devices) used.

## Parameter page 1

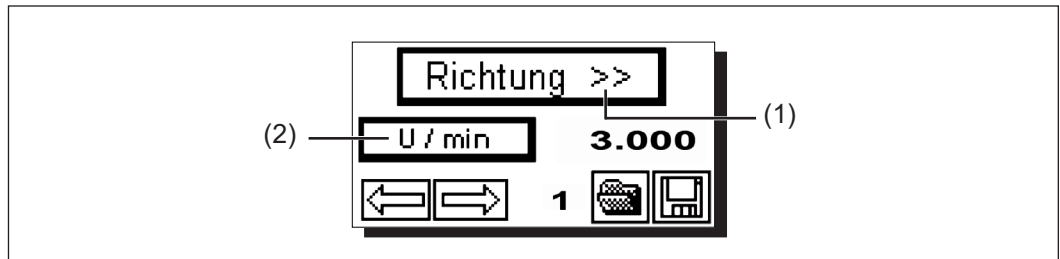

---

### (1) Direction << >>

Defines the direction of rotation of the rotation table face plate in automatic and manual mode. Pressing the start and stop buttons simultaneously also changes the direction.

**Important!** Changing the direction in the service parameters also changes the direction.

Unit: -

Setting range: Anti-clockwise rotation, clockwise rotation

Factory setting: Clockwise rotation

---

### (2) Speed of rotation in rpm

Defines the speed of rotation of the rotation table face plate.

Unit: rpm

Setting range: depends on rotation table (please see rating plate)

Factory setting: 3

---

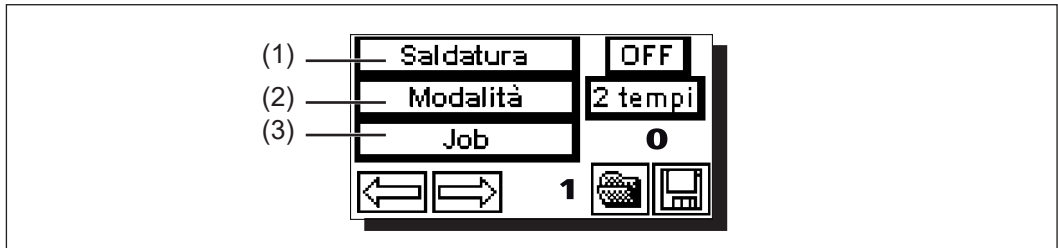

**(1) Welding ON/OFF**

For preselecting whether to run the automatic program sequence with or without welding. The welding ON/OFF selector switch (5) must also be switched to "ON" during a sequence where welding takes place.

Unit: -  
 Setting range: OFF / ON  
 Factory settings: OFF

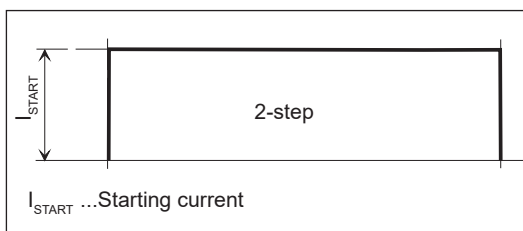

**(2) 2-step mode**

Operating mode for the automatic program sequence.

The amperage ( $I_{START}$ ) must be set on the power source.

Starting current and duration as well as final current and duration must also be set on the power source (special 2-step mode).

**(3) Job**

When using a robot interface, ready made jobs may be called up from the power source via the FCU-20 control unit. Jobs that can be called up: 0, 1, 2, 3.

**Important!** For "Job" mode, the "Rob" service parameter must be set to ON.

Unit: -  
 Setting range: 0 - 3  
 Factory settings: 0

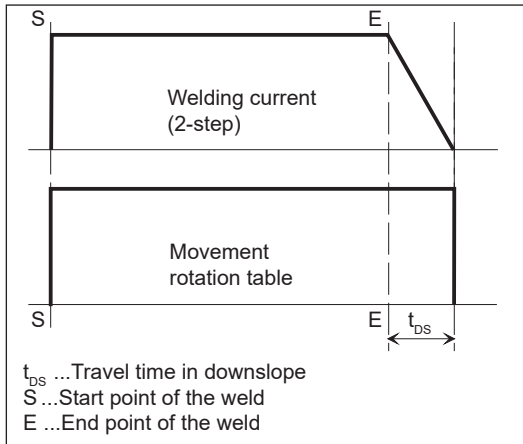
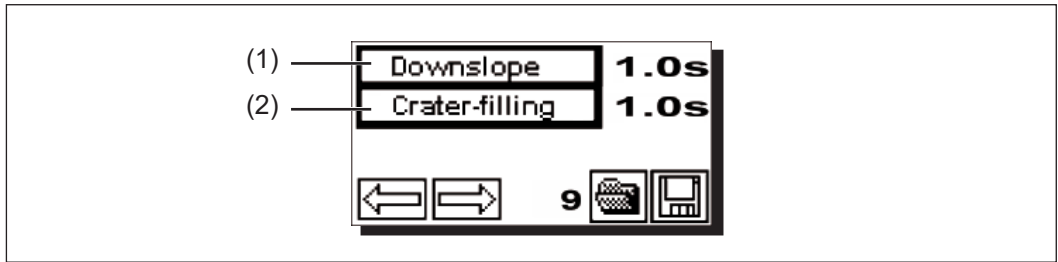

**(1) Downslope**

$t_{DS}$  ... Duration of welding movement in the welding current downslope phase. The rotation table continues to move after the end point of the weld (determined by cam). The downslope for the welding current must be set at the power source.

Unit: s  
 Setting range: 0.0 - 60.0  
 Factory setting: 1.0

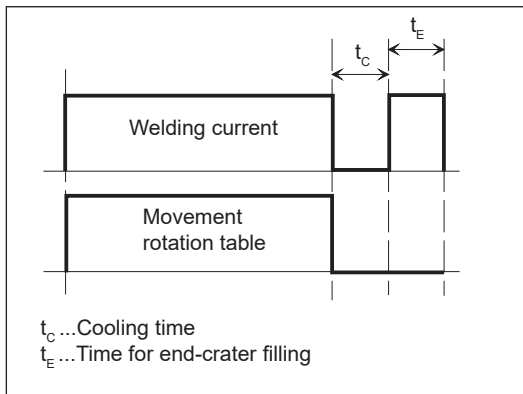

**(2) Crater-filling**

$t_C$  ... Length of time that the arc remains on at the end of the weld seam in order to fill the crater. The arc is ignited again for the duration of the crater filling process after the cooling time  $t_C$  has elapsed.

Unit: s  
 Setting range: 0.0 - 60.0  
 Factory setting: 0.0

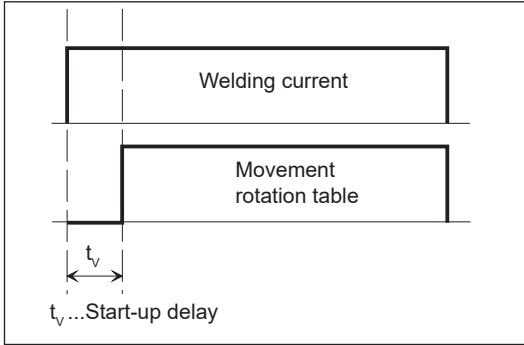

**(1) Start-up delay**

$t_v$ ... Time between arc ignition and the start of welding movement.

Unit: s  
 Setting range: 0.0 - 60.0  
 Factory setting: 0.0

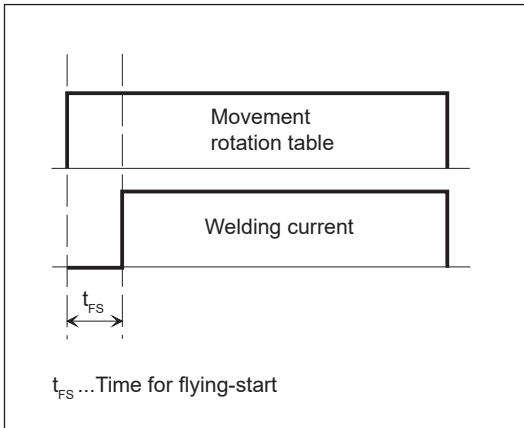

**(2) Flying-start**

$t_{FS}$ ... Time delay between the start of the rotational movement and the ignition of the arc. The rotary movement is not stopped while the arc is igniting. Advisable when welding thin pipes to minimise heat input in the start-up phase.

Unit: s  
 Setting range: 0.0 - 60.0  
 Factory setting: 0.0

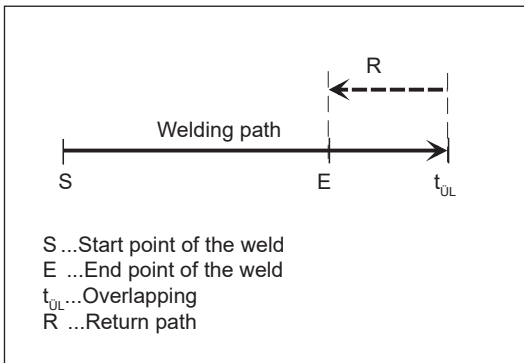

**(3) Overlapping**

$t_{OL}$  ... Length of time that welding continues beyond the end point (marked by cam). This allows the start of the weld seam to be overlapped in the case of circumferential welds. After welding has finished, and the cooling time has elapsed, the rotation table returns automatically to the end point of the weld (at high speed, and with no welding).

Unit: s  
 Setting range: 0.0 - 60.0  
 Factory setting: 0.0

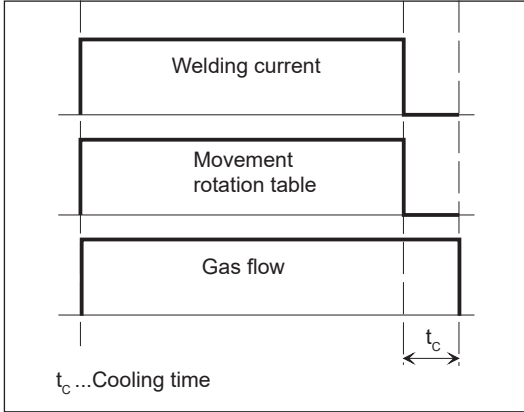

**(1) Cooling time**

$t_c$ ... Length of time that the torch should dwell over the end of the weld seam to allow the seam to cool under the shielding gas. Once this cooling time has elapsed, the time for crater filling starts.

**Important!** The cooling time is observed again after the end crater has been filled.

Unit: s  
 Setting range: 0.0 - 60.0  
 Factory setting: 3.0

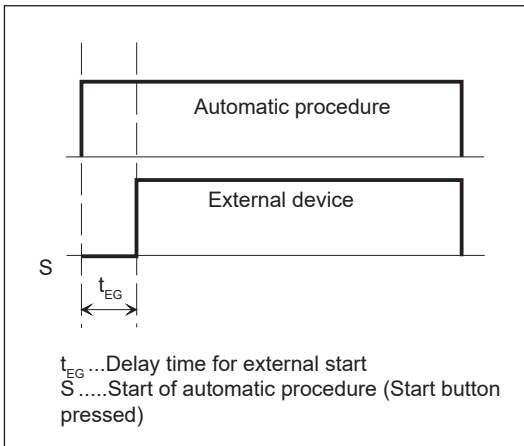

**(2) External start**

$t_{EG}$ ... Start signal delay when starting an external device (e.g. cold wire feeder, oscillation unit, AVC, etc.).

Unit: s  
 Setting range: 0.0 - 99.0  
 Factory setting: 0.0

**(3) Successor prg.**

Enter one of 99 successor programs. Once the currently loaded program has finished, the successor program is loaded and started.

Unit: -  
 Setting range: 00 - 99  
 Factory setting: 00

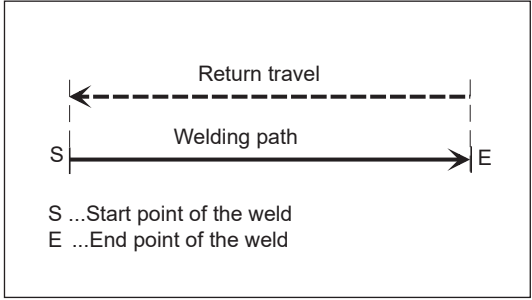
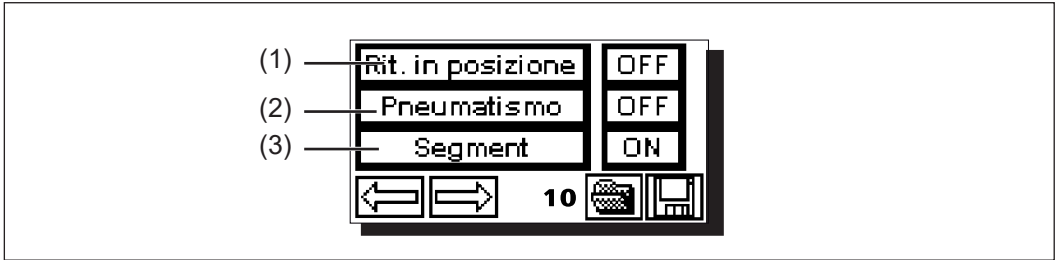

**(1) Return travel ON/OFF**  
 Activates/deactivates the automatic return travel of the rotation table from the end point of the weld to the start point. Return travel takes place at high speed, and with no welding.  
 Unit: -  
 Setting range: ON / OFF  
 Factory setting: OFF

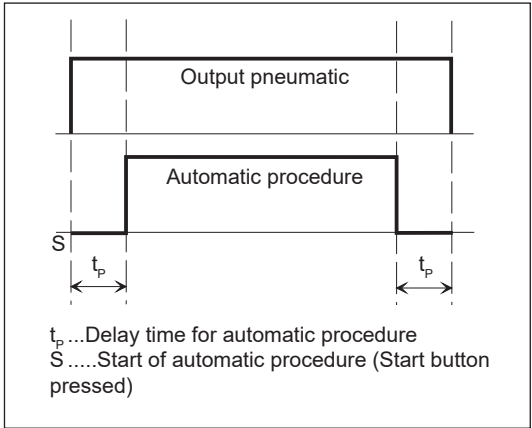

**(2) Pneumatic ON/OFF**  
 Activates/deactivates optional pneumatic equipment (pneumatic torch positioning) for automatic welding. There is a set delay between pressing the start button and the start of the automatic procedure to allow the torch sufficient time to move into position. Activating the "Pneumatic UP/DOWN" parameter tests the unit. Advisable before starting an automatic welding process to check the position of the torch in relation to the component.  
 Unit: -  
 Setting range: ON / OFF  
 Factory setting: OFF

**(3) Segment ON/OFF**  
 To activate/deactivate segment mode. This parameter enables certain programs to be linked together. For further information on program linking, see the "Segment mode" section.  
 Unit: -  
 Setting range: ON / OFF  
 Factory setting: ON

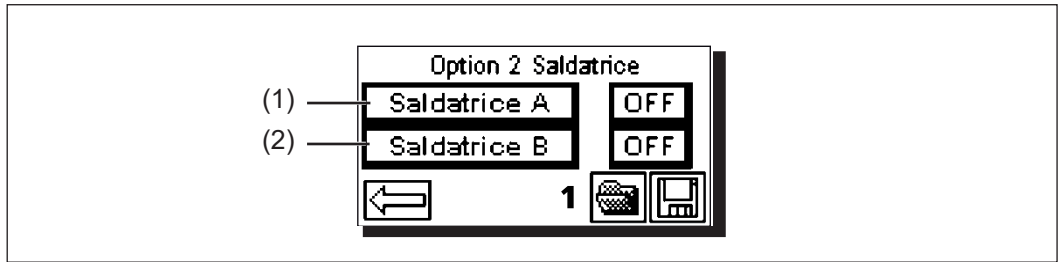

**(1) 2 power sources option - power source A**

Activates/deactivates power source A.

"2 power sources option".... optional parameter for controlling two power sources.

**Important!** Service parameter "DOWN" must be set to ON to activate or deactivate power source A (see *Service parameters*).

Unit: -  
 Setting range: OFF/ON  
 Factory setting: OFF

**(2) 2 power sources option - power source B**

Activates/deactivates power source B.

"2 power sources option".... optional parameter for controlling two power sources.

**Important!** Service parameter "DOWN" must be set to ON to activate or deactivate power source B (see *Service parameters*).

Unit: -  
 Setting range: OFF/ON  
 Factory setting: OFF

**Parameter page - pneumatic test**



**Note!** The following parameter page is called up from "Parameter page 1" using the left arrow key.

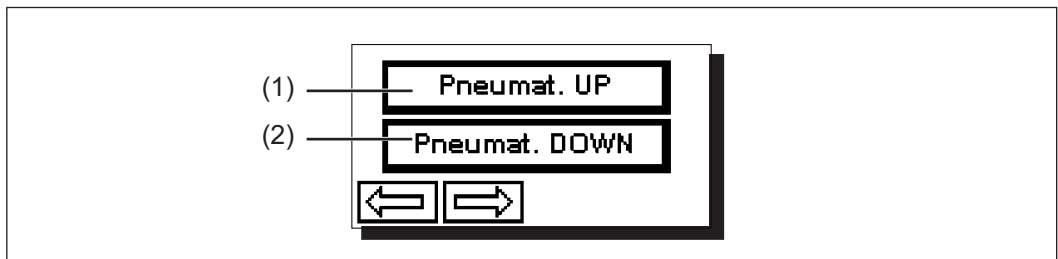
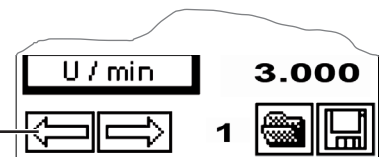

**(1) Pneumatic - UP**

For testing the pneumatic unit (raising pneumatic torch position). Advisable test function before starting an automatic welding process, for checking the position of the torch in relation to the component.

Unit: -  
 Setting range: No status indicator  
 Factory setting: -

**(2) Pneumatic - DOWN**

For testing the pneumatic unit (lowering pneumatic torch position). Advisable test function before starting an automatic welding process, for checking the position of the torch in relation to the component.

Unit: -  
 Setting range: No status indicator  
 Factory setting: -

# Parameter calibration

## General

To accelerate the whole process, it is advisable to calculate the parameter values automatically. The following parameters can be coordinated:

- Speed of rotation in rpm
- Workpiece diameter in mm
- Welding speed in cm/min



**Note!** Two values are always required to calculate a parameter.

## Procedure

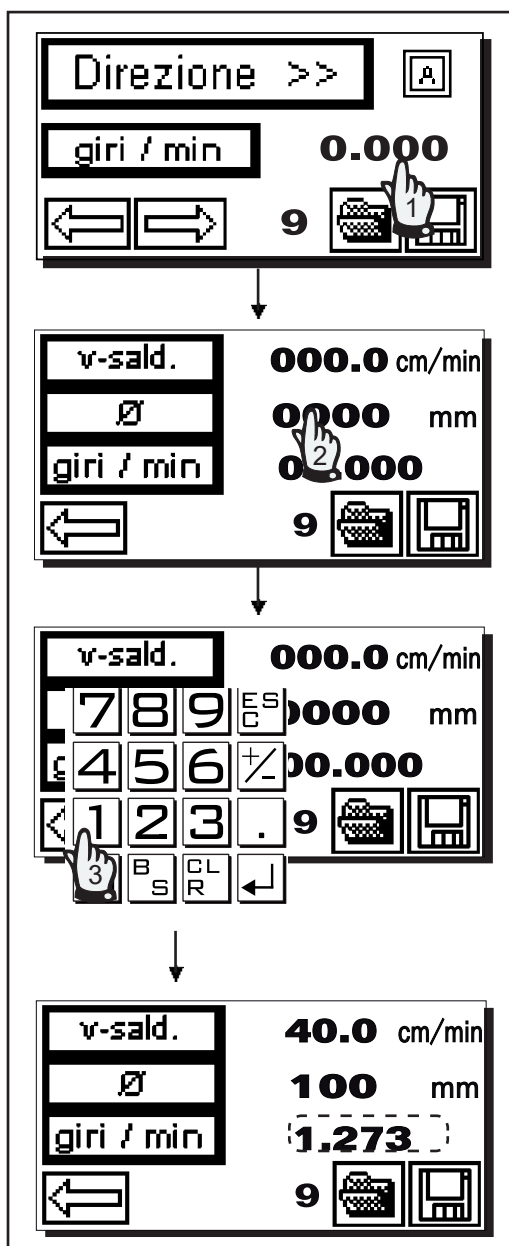

1. Press the value for speed of rotation; the parameter calculation screen opens.
2. Press value for workpiece diameter. The numerical pad opens.
3. Type in the desired value for the workpiece diameter and press Enter. Alternatively, press the previously selected value again. Repeat the procedure using the v-welding parameter.
4. The recalculated value for speed of rotation is shown in rpm.

**Important!** The speed of rotation can only be adjusted in the mains screen (parameter page 1) using the multifunction wheel. A value for the workpiece diameter must exist before the welding speed (v-Welding) can be calculated.



# Program management

## General

The FCU-20 control unit allows the user to save and load up to 99 complete parameter lists. The working parameters created for one single component can be saved using a program number selected by the user. These parameter lists can be reloaded at any time, and corrected as required. Programs can be saved and loaded from any parameter page.

## Saving welding programs

After successfully entering the required working parameters, the whole list can be saved.



**NOTE!** If a parameter list is saved under a pre-existing program number, the parameters in this list are overwritten.

Once the values for the working parameters have been entered, carry out the following procedure:

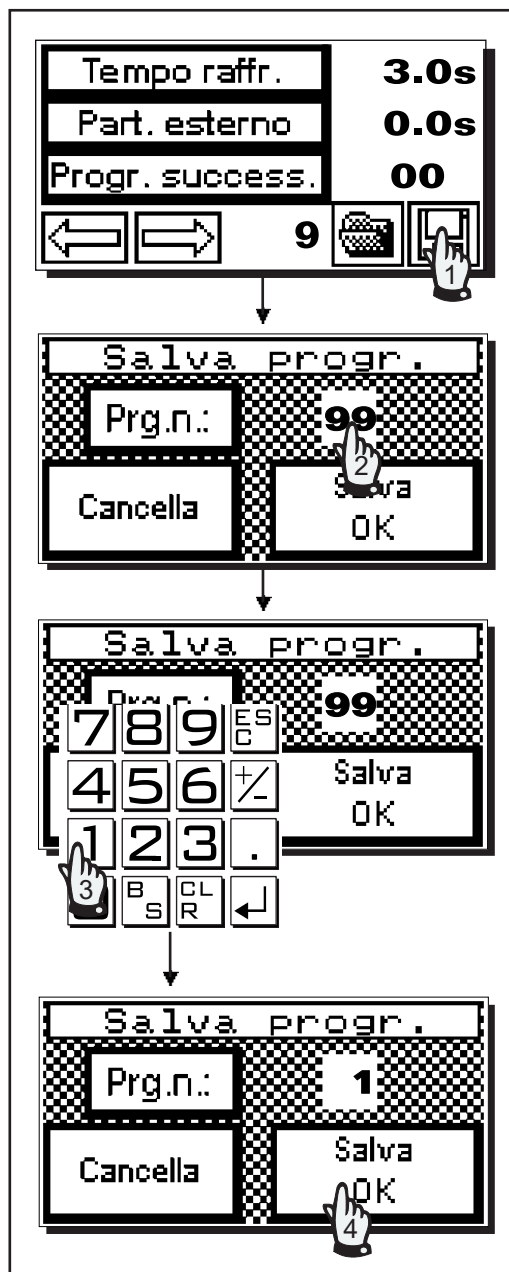

Saving programs

1. Briefly press the touch button for saving programs (diskette symbol) - the "Prg. save" page appears.
2. Press the program number field, the numerical pad opens.
3. Enter the desired program number using the numerical pad and confirm by pressing Enter. Alternatively, press the previously selected value again.
4. Press the "Save OK" touch button to apply the selected program. Press the "Cancel" touch button to cancel this procedure.

## Loading welding programs

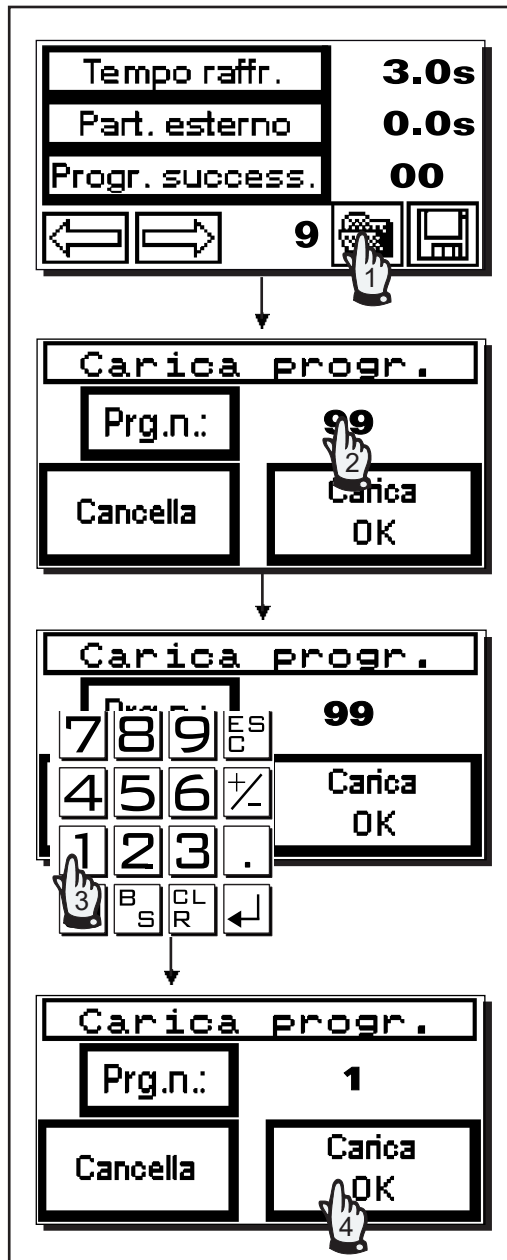

Loading programs

1. Briefly press the touch button for loading programs (folder symbol) - the "Load program" page appears.
2. Press the program number field, the numerical pad opens.
3. Enter the desired program number using the numerical pad and confirm by pressing Enter. Alternatively, press the previously selected value again.
4. Press the "Load OK" touch button to load the selected program. Press the "Cancel" touch button to cancel this procedure.



**NOTE!** Successor programs may be defined (see page 15, point 3). Once the currently loaded program has finished, the successor program is loaded and started.

# Segment mode

## General

Welding programs may also be linked in order to cover more complex requirements (see page 15, point 3). This is always necessary if different welding parameters are required for a particular section of a welding path, or various other settings are required. The FCU-20 control unit provides two segment modes (Segment ON, Segment OFF) as described below.



**NOTE!** The functions described here are only available in conjunction with the "Rob 3000" interface.

## Segment ON mode

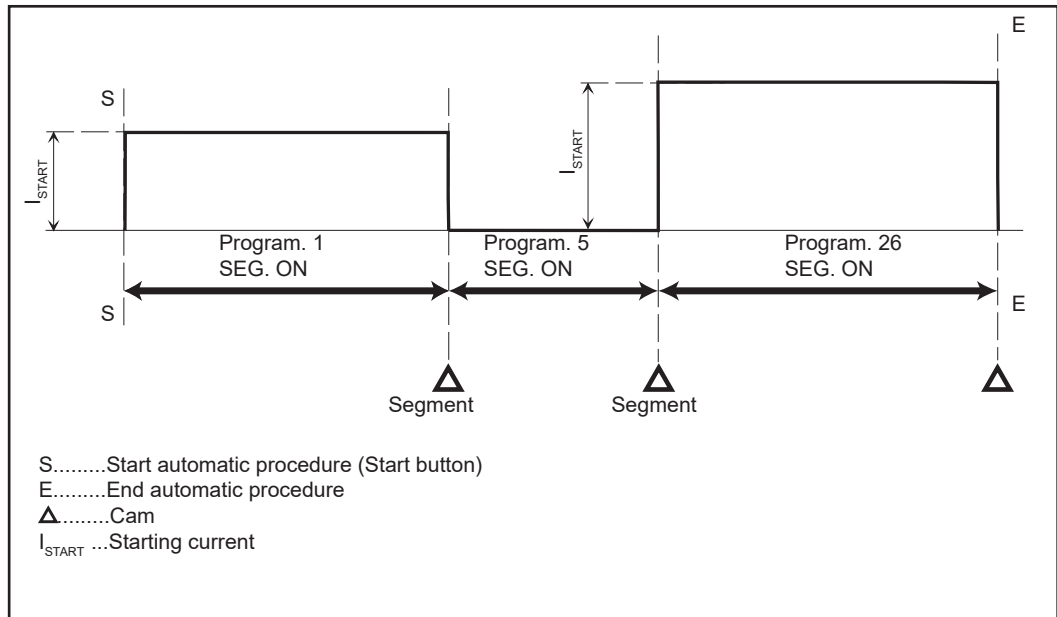

Program chain in SEGMENT ON mode with Rob 3000 interface

### Segment ON

If segment mode is set to "ON", the complete parameter list of the saved program is processed when programs are linked. As shown in the above application, this program chain consists of three programs, Prg. 1, Prg. 5 and Prg. 26. Prg. 5 does not involve any welding, so represents a pause. However, all the parameters in this program are processed. Once the cam is reached, the currently running program is ended (end parameter) and the successor program is loaded. The transition from one program to the next is automatic.

In the final program in the chain, it is advisable to set the "return travel" parameter to ON. The unit then returns automatically to the start of the whole program chain (S).



**NOTE!** To ensure the automatic transition from one program to the next in this mode, all programs in the chain must be set to Segment "ON".

## Segment OFF mode



**NOTE!** The functions described here are only available in conjunction with the "Rob 3000" interface.

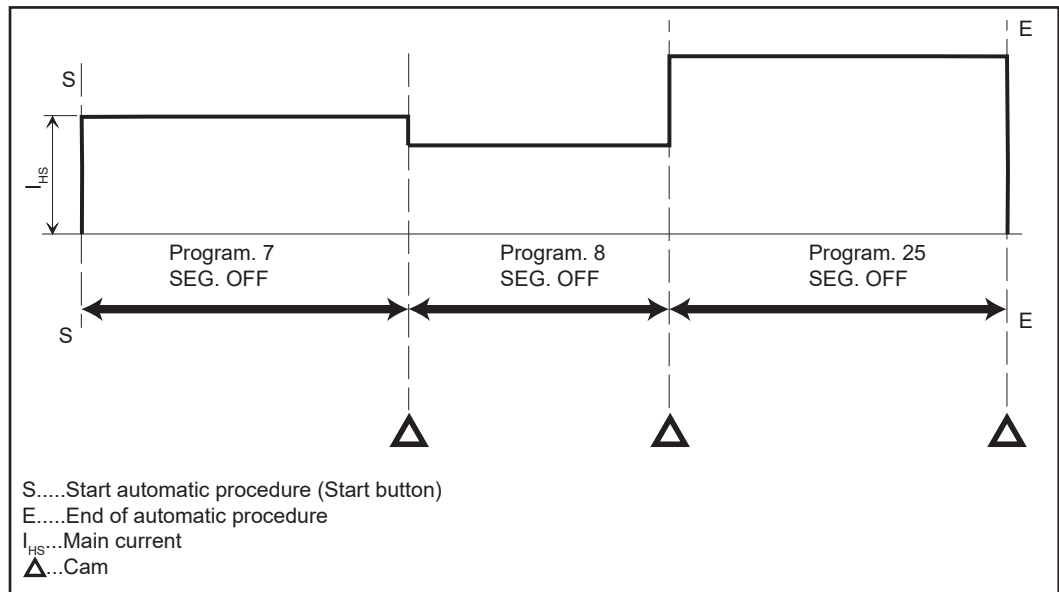

Program chain in SEGMENT OFF mode with Rob 3000 interface

### Segment OFF

If, in a program chain, segment mode is set to "OFF", the settings of each program are skipped when moving from one program to the next. As shown in the application above, this program chain also consists of three programs, Prg. 7, Prg. 8 and Prg. 25. Once the cam is reached and the transition to the next program has taken place, (e.g. Prg. 7 --> Prg. 8), the parameters are skipped, and the different speed or job setting is applied immediately ( ... only main current is changed).

In the final program in the chain, it is advisable to set the "return travel" parameter to ON. The unit then returns automatically to the start of the whole program chain (S).



**NOTE!** To ensure the program transition in this mode takes place as expected, all programs in the chain must be set to segment "OFF".

## Description of pedal remote control

### FRC-1



FRC-1 pedal remote control

### FRC-1

Two functions are available (see "Service parameters" for the presettings required for each function):

**Inching mode:** The process continues automatically for as long as the pedal is depressed.

**Permanent operation:** Press the pedal briefly to start the automatic process. Press it again to stop the process.

# Service parameters



## General

The FCU-20 control unit service parameters provide the user with the following options:

- Display the PLC inputs and outputs
- Select the preferred language for the display (German, English, Spanish or Italian)
- Calibrate the command and actual values for traversing path and speed
- Direction preselection
- Robot interface activation option
- Activate 2 power sources option
- Activate current flow signal
- Select FRC 1 inching mode/permanent operation

## Navigation

While in the service parameter pages, the user can only switch to other pages by pressing the following touch buttons:

	- Scroll to the next page
	- Scroll to the previous page
	- Escape to main menu (parameter page 1)

## Calling up service parameters

To call up the service parameter pages, press the stop button for > 5 seconds.

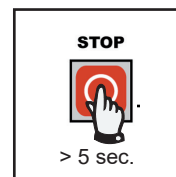

## Parameter page 1 - PLC inputs and outputs

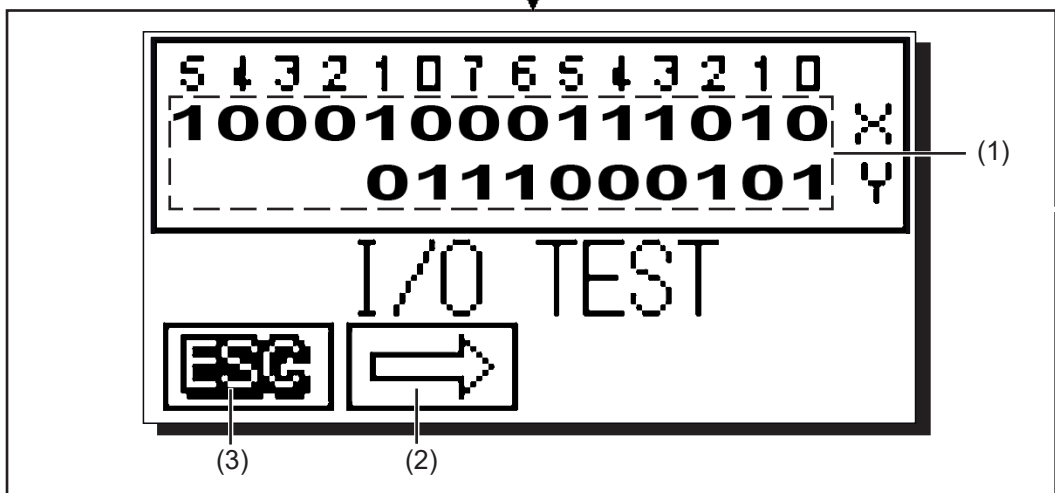

PLC inputs and outputs display

(1) **PLC inputs and outputs status display**

(2) **Button →**

Scroll to the next page by pressing this arrow button.

(3) **ESC button**

Switch to the main menu by pressing this button (parameter page 1).

**PLC list of inputs and outputs**

Status of PLC inputs and outputs	
0	0V
1	24V DC
PLC inputs	
X0	Multifunction wheel A
X1	Multifunction wheel B
X2	Manual mode button -
X3	ES segment (Prg. step)
X4	Reserve
X5	Manual mode button +
X6	Limit switch 360 °
X7	Emergency stop
X10	Start button
X11	Stop button
X12	Welding On/Off
X13	FRC start
X14	Press on multifunction wheel
X15	Current flow signal
PLC outputs	
Y0	Actual value
Y1	Power source B
Y2	Motor left
Y3	Motor right
Y4	High speed
Y5	External start
Y6	Pneumatic
Y7	Power source A
Y10	Job
Y11	Job

**Parameter page 2 - Language selection**



Language selection

**(1) Language selection**

For selecting a new display language. Simply press the appropriate touch button to select the desired language. The language is applied immediately and the display text now appears in the selected language.

**Parameter page 2**  
**- Language selection (continued)**

**(2) Contrast**

Press this button to open the "Display" selection window. Press the desired display parameter to select it. The respective adjustment window then opens.

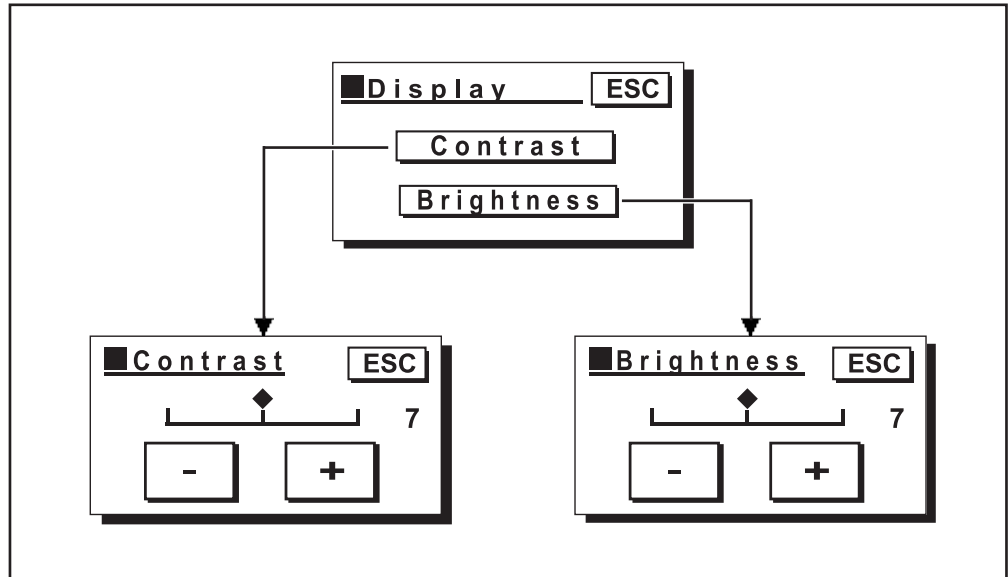

Increase or decrease the display contrast or brightness value by pressing + or -. Changed values are reflected immediately on the display. Once the correct setting has been made, press the Escape button to apply the settings.

Unit: -  
 Setting range: 0 - 14  
 Factory setting: 7

**Parameter page 3**  
**- Power source**

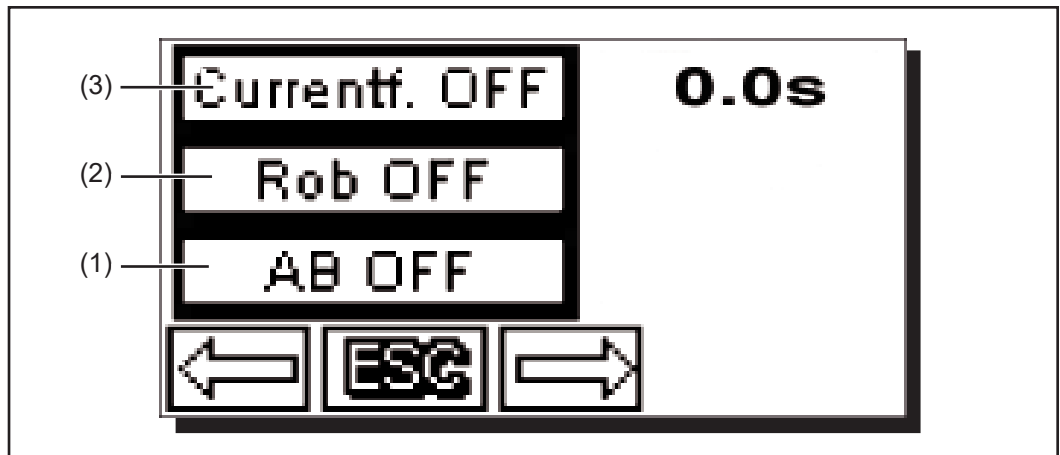

*Power source service parameter*

**(1) DOWN ON/OFF**

For activating/deactivating the "2 power sources option" parameter.

**(2) Rob ON/OFF**

For activating/deactivating the robot interface option. When activated, jobs can be called up from the digital power source.

**(3) Currentfl. ON/OFF**

Activates/deactivates the power source current flow signal query. When activated (Currentfl. ON), an extended query time for the current flow signal can be set.

Unit: s (seconds)  
 Setting range: 0-10  
 Factory setting: 0.0

Parameter page  
4 - Calibration

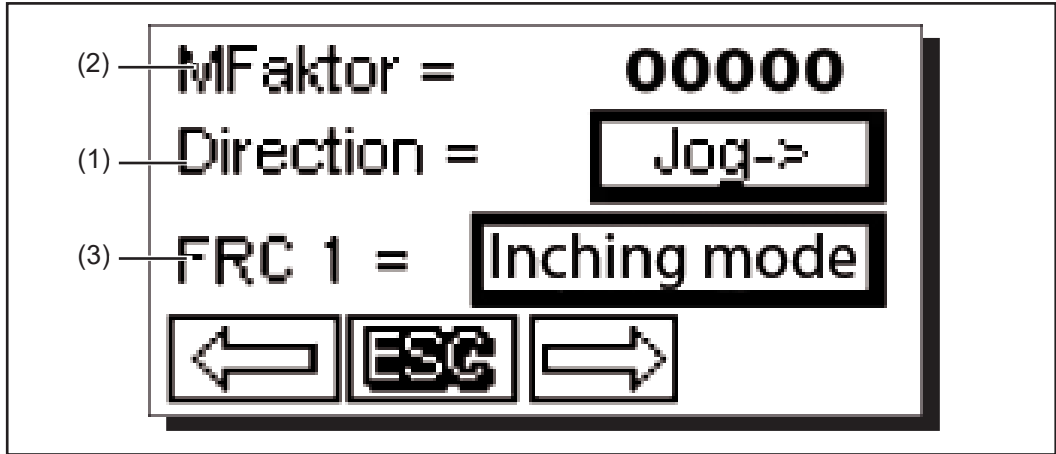

Calibration parameters

(1) **Direction**

Manual mode + automatic mode direction. The direction can be changed, for example when the rotation table is in a specific position.

(2) **MFaktor**

Multiplication factor - Defines the maximum speed of rotation of the rotation table.

(3) **FRC 1**

Preselect "Inching mode" or "Permanent operation".

Parameter page  
5 - Hardware

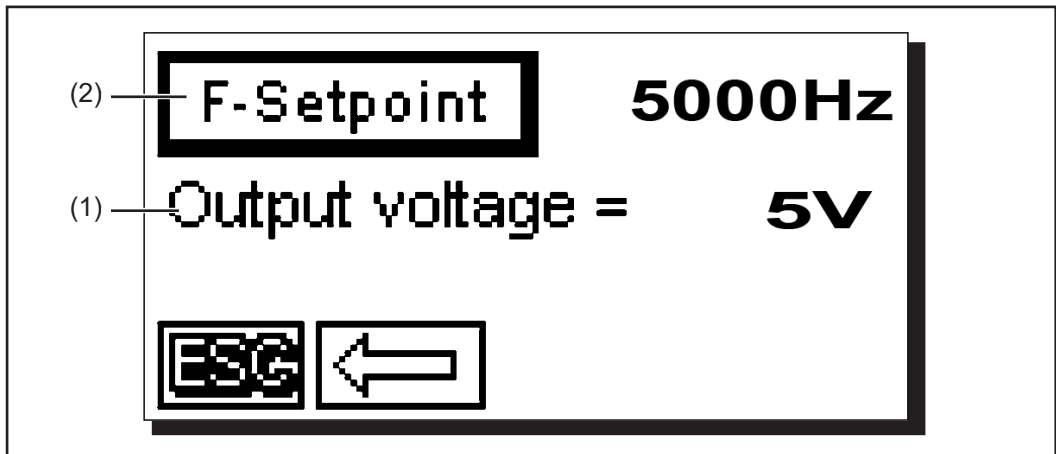

Hardware parameters

(1) **Output voltage**

Output voltage - for matching the control unit to whichever hardware is connected (e.g. rotation table).



**NOTE!** This value is a factory setting and cannot be changed.

(2) **F-Setpoint**

Hardware-dependent command value for the installed frequency converter.



**NOTE!** This value is a factory setting and cannot be changed.



## Decommissioning



**Note!** Some control settings may be lost if the device is not used for an extended period of time. Before starting up the device again, we advise that the "MFaktor" and "Output voltage" values are checked against the following table and corrected if necessary.

### Data table FCU-20

Device	MFaktor <sup>1)</sup>	F-Setpoint	Output voltage
FTT-10	10500	5000	5V
FTT-40	12000	5000	5V
FTT-150	6450	5000	5V
FRT-150	5600	5000	5V
FRT-50	7400	5000	5V
FRP -150	5620	5000	5V

### Data table FCU-20.0

Device	MFaktor <sup>1)</sup>	F-Setpoint	Output voltage.
FTT 380 - 1500	1400	5000	10V
FTT 3000 - 7500	1000	5000	10V
FTT 12000	1000	5000	10V
FRT 1000	2000	5000	10V
FRT 2000 - 5000	1500	5000	10V
FRT 10000	1000	5000	10V

### Calculating the MFaktor

<sup>1)</sup> The value „MFaktor“ may differ. It is recommended to match this value with the rating plate of the rotation table in use.

A-4600 Wels www.fronius.com		Art.No.: [redacted]	
		Ser.No.: [redacted]	
EN 12100			
 50/60 Hz	U <sub>1</sub>	I <sub>1</sub>	P
	230 V	0,8 A	0,18 kVA
	V <sub>max</sub>	max. load	weight
	11 rpm	40 kg	85 kg
L x W x H			
490 x 490 x 595 mm			

Rating plate rotation table

Calculating the MFaktor:

On the rating plate of the rotation table, the value  $V_{max}$  is specified. The value of MFaktor results according to the following formula:

$$V_{max} \times 1000$$

Example:

$$11 \times 1000 = \text{MFaktor } 11000$$

# Troubleshooting

## Safety



**WARNING!** An electric shock can be fatal. Before opening the device:

- Move the mains switch to the - O - position
- Unplug the device from the mains
- Put up an easy-to-understand warning sign to stop anybody inadvertently switching it back on again
- Using a suitable measuring device, check that electrically charged parts (e.g. capacitors) have been discharged



**CAUTION!** Inadequate PE conductor connections can cause serious injury and damage. The housing screws provide a suitable PE conductor connection for earthing the housing and must NOT be replaced by any other screws that do not provide a reliable PE conductor connection.

## General

Basic requirements to ensure a fully-functioning system:

- Connections established between separate system components
- System components are supplied with electricity and the mains voltage is as specified (see rating plate)

## Troubleshooting

Errors	Cause	Remedy
The rotation table does not move	Data loss	Correct the data according to the table, see page 27

## Error messages

<b>EMERGENCY STOP</b>	<b>EMERGENCY STOP</b>
	Activated by the emergency stop protection device. All control elements are disabled during an emergency stop.
<b>Cause:</b>	<b>Remedy:</b>
The Emergency Stop protection device on the FCU-20 control unit was activated because of an emergency.	Rectify emergency stop situation and reset emergency stop button Contact Fronius service personnel.
Fault in the installed frequency converter.	Contact Fronius service personnel.

<b>Screen No. Error</b>	<b>Screen Number Error</b>
	See page 24 - Language selection: this error can be caused by pressing "..." if this language is not available in the software.
<b>Cause:</b>	<b>Remedy:</b>
No valid language selected.	Choose a language.

**Error messages  
(continued)**

<b>No current flow signal</b>	<b>No current flow signal</b>
	No current flow signal detected from the power source (no voltage connection)
<b>Cause:</b>	<b>Remedy:</b>
No arc ignition	Clean surface of the workpiece, re-ignite the arc
Fault on the power source	Check power source settings and correct if necessary
No robot interface in use	Integration of ROB3000 robot interface
Faulty connection to power source	Check connection to the power source
Welding material not connected	Connect welding material

<b>No screen data</b>	<b>ERFF</b>	<b>No screen data + ERFF</b>
<b>Cause:</b>		<b>Remedy:</b>
Display GT01 is not programmed.		Program display. This can only be performed by the manufacturer.

<b>ERFF</b>	<b>ERFF</b>
	Communication fault
<b>Cause:</b>	<b>Remedy:</b>
No connection between PLC and display.	<ul style="list-style-type: none"> <li>• Check wiring and cables</li> <li>• PLC switch is set to STOP - switch to RUN.</li> </ul>









	<b>Display in Standby mode</b>
	No communication over the display is possible, no error display
<b>Cause:</b>	<b>Remedy:</b>
PLC is not programmed or is faulty.	Reprogram or replace PLC (this can only be performed by the manufacturer)

# Technical data

## FCU-20 technical data

Mains voltage	230 V
Mains frequency	50/60 Hz
Mains fuse	1.5 A
Control voltage	24 V
Power consumption	230 VA
Nominal current	1 A
Dimensions (l x w x h)	350 x 235 x 160
Weight	5 kg

## Rating plate FCU-20 / 20.0

 A-4600 Wels www.fronius.com		Art.No.:	
		Ser.No.:	
IP23			
 <small>50/60 Hz</small>	U <sub>1</sub>	I <sub>1</sub>	
	230 V	1 A	1,5 A
	U <sub>2</sub>	I <sub>2</sub>	P
	24 VDC	0,4 ADC	230 VA
 		  	

# Spare parts list FCU-20

## FCU-20 spare parts list

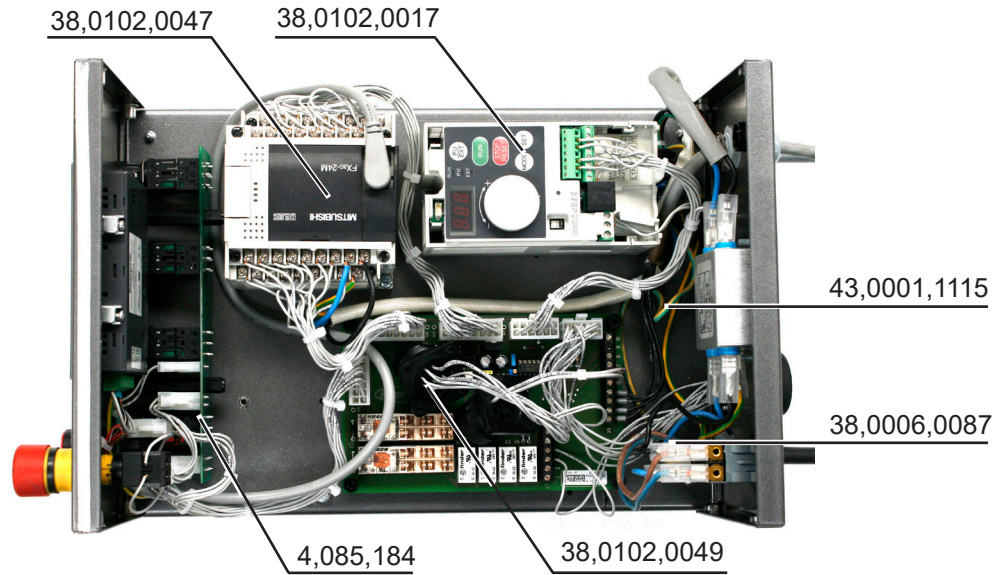
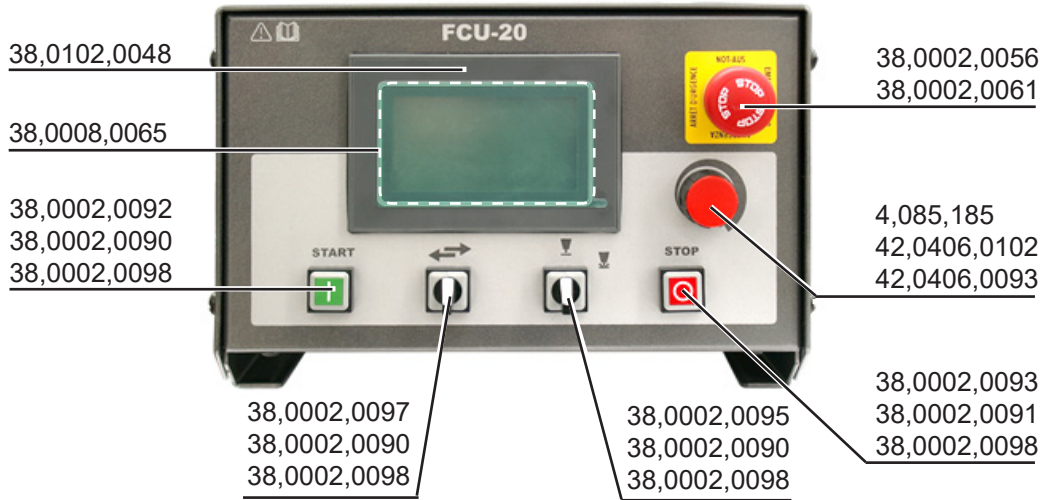

**FCU-20 spare parts list**  
(continued)

<b>Item number</b>	<b>Name</b>
8,040,073	FCU-20
4,085,184	TP FCU/FRC PC board
4,085,185	DGP PC board
38,0102,0049	MP FCU-20
38,0002,0061	N.C. contact element emergency stop
38,0002,0090	N.O. contact element
38,0002,0091	N.C. contact element
38,0002,0092	Start button
38,0002,0093	Stop button
38,0002,0095	Toggle switch
38,0002,0097	Manual mode button
38,0002,0098	Mounting flange
38,0006,0087	Mains switch
38,0102,0017	Frequency converter
38,0008,0065	Touchscreen display protective film
38,0002,0056	Emergency Stop button
38,0102,0047	PLC control
38,0102,0048	Touchscreen display
38,0100,0187	Hosepack
38,0100,0219	Tuchel connecting lead
42,0406,0093	Red cover
42,0406,0102	Black adjusting knob
43,0001,1115	Line filter
43,0004,3206	5 m mains cable

# Accessories and options FCU-20

## System overview

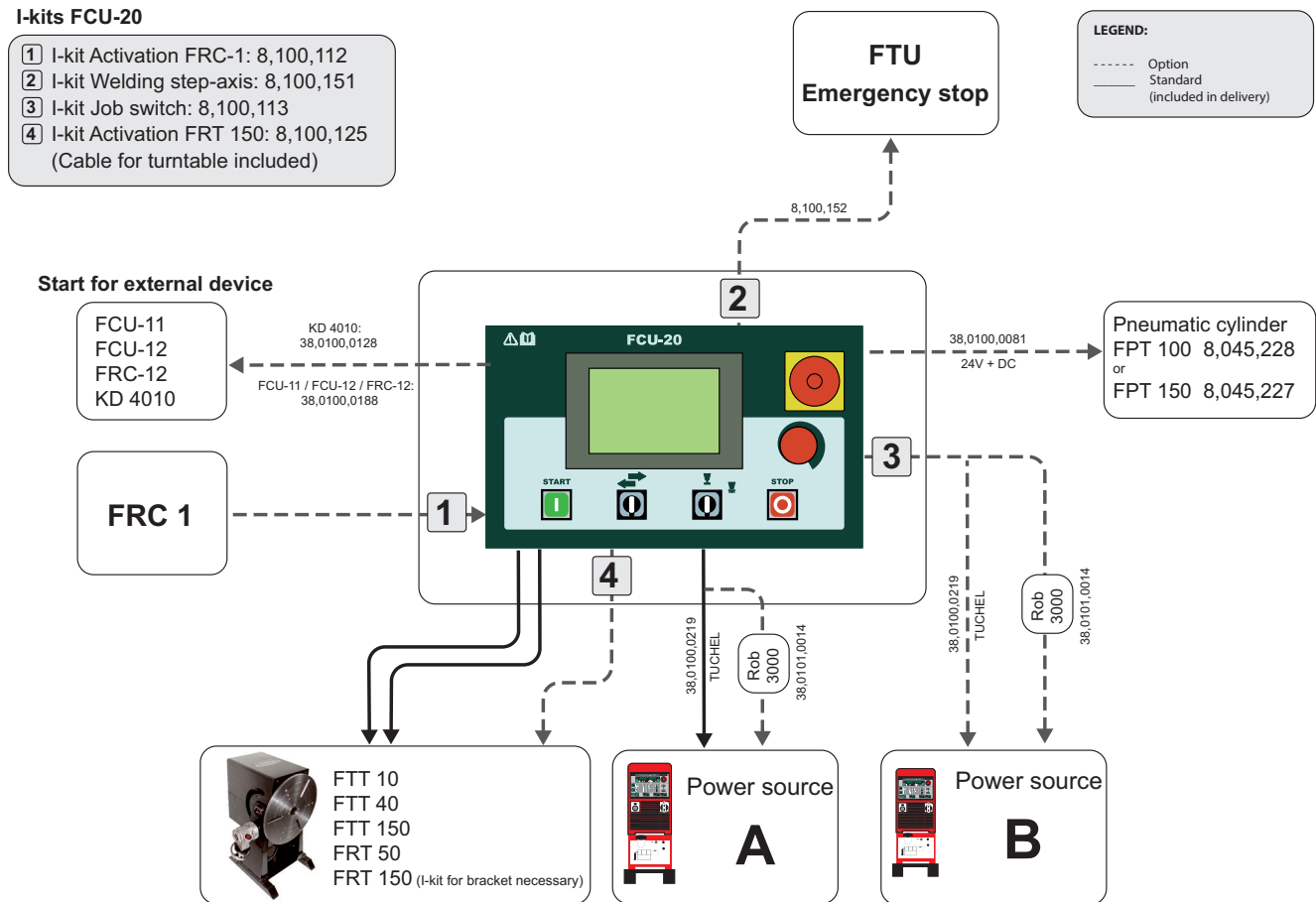

### Installation kit

- I-kit, start/stop A/B or A and B (for 2 welding power sources), (factory installation).  
Item number: 8,100,113
- I-kit, controller for FRC-1 pedal remote control (factory installation).  
Item number: 8,100,112
- I-kit, FCU offset axis (only in conjunction with FTU tripod unit and FTU offset axis I-kit 8,100,152).  
Item number: 8,100,151
- I-kit, FRT 150 (only in conjunction with FRT 150 rotation table)  
Item number: 8,100,125

### Pedal remote control

FRC-1 with 3 m cable and protection.  
Item number: 8,045,011

### Connecting lead

- Connecting lead 5 m, FCU-20 to FPT (pneumatic torch positioning).  
Item number: 38,0100,0081
- Connecting lead 5 m, FCU-20 to FCU-11, FCU-12.  
Item number: 38,0100,0188
- Connecting lead 3 m, FCU-20 to KD-4010.  
Item number: 38,0100,0128

# Spare parts list FCU-20.O

## FCU-20.O spare parts list

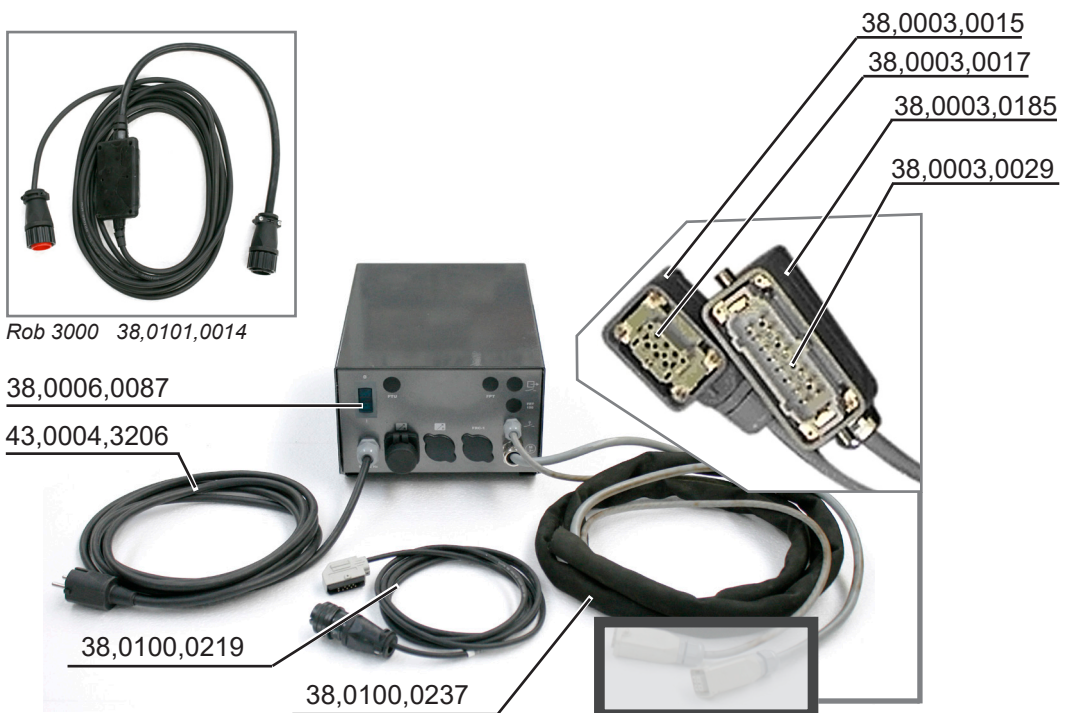
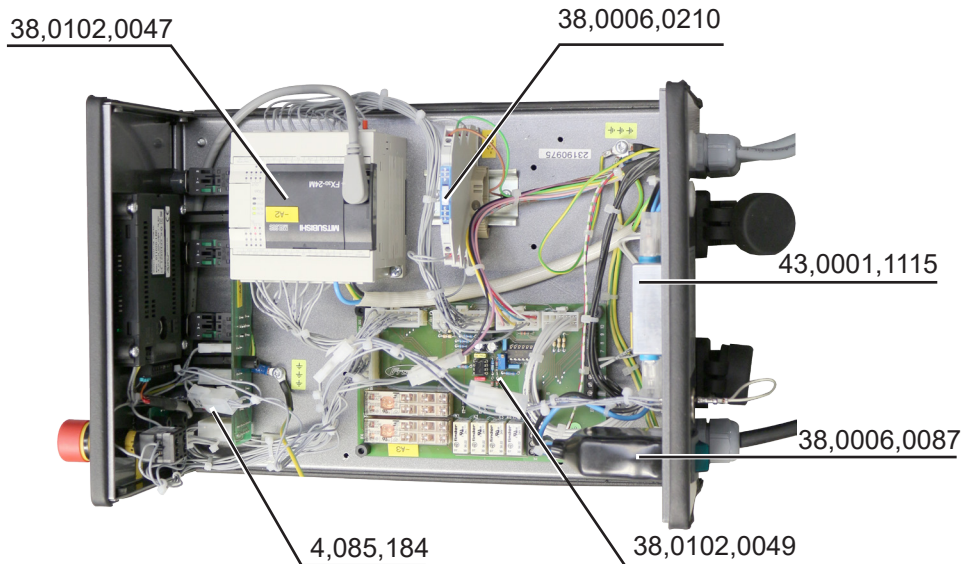
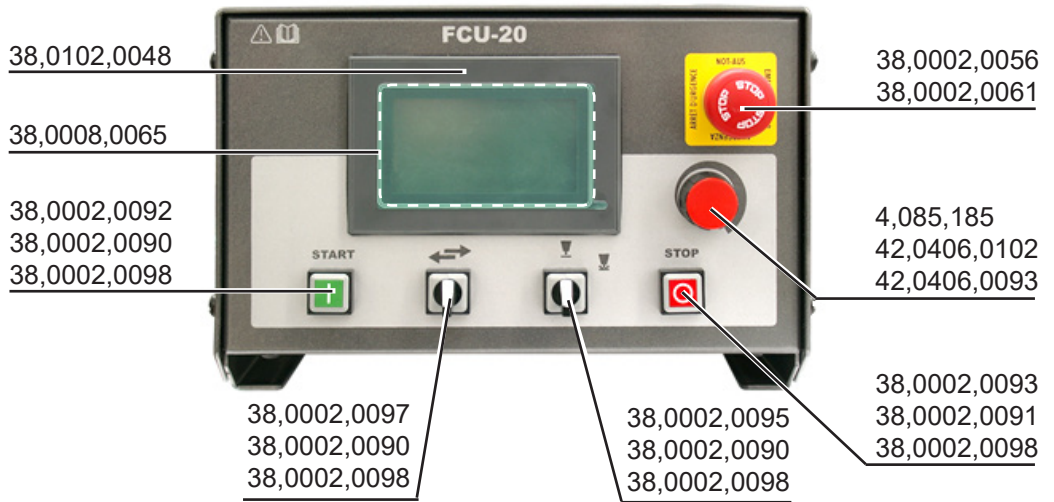



**FCU-20.O spare parts list**  
(continued)

<b>Item number</b>	<b>Name</b>
8,040,073,630	FCU-20.O
4,085,184	TP FCU/FRC PC board
4,085,185	DGP PC board
38,0102,0049	MP FCU-20
38,0002,0061	N.C. contact element emergency stop
38,0002,0090	N.O. contact element
38,0002,0091	N.C. contact element
38,0002,0092	Start button
38,0002,0093	Stop button
38,0002,0095	Toggle switch
38,0002,0097	Manual mode button
38,0002,0098	Mounting flange
38,0003,0015	Attachment housing
38,0003,0017	Bush insert
38,0003,0029	Bush insert
38,0003,0185	Attachment housing
38,0006,0087	Mains switch
38,0008,0065	Touchscreen display protective film
38,0002,0056	Emergency Stop button
38,0102,0047	PLC control
38,0006,0210	Galvanic insulator
38,0102,0048	Touchscreen display
38,0100,0237	Hosepack
38,0100,0219	Tuchel connecting lead
42,0406,0093	Red cover
42,0406,0102	Black adjusting knob
43,0001,1115	Line filter
43,0004,3206	5 m mains cable

# Accessories and options FCU20.0

## System overview

### I-kits FCU-20.0

- ① I-kit Activation FRC-1: 8,100,112
- ② I-kit Welding step-axis: 8,100,151
- ③ I-kit Job switch: 8,100,113

### LEGEND:

- Option
- Standard
- (included in delivery)

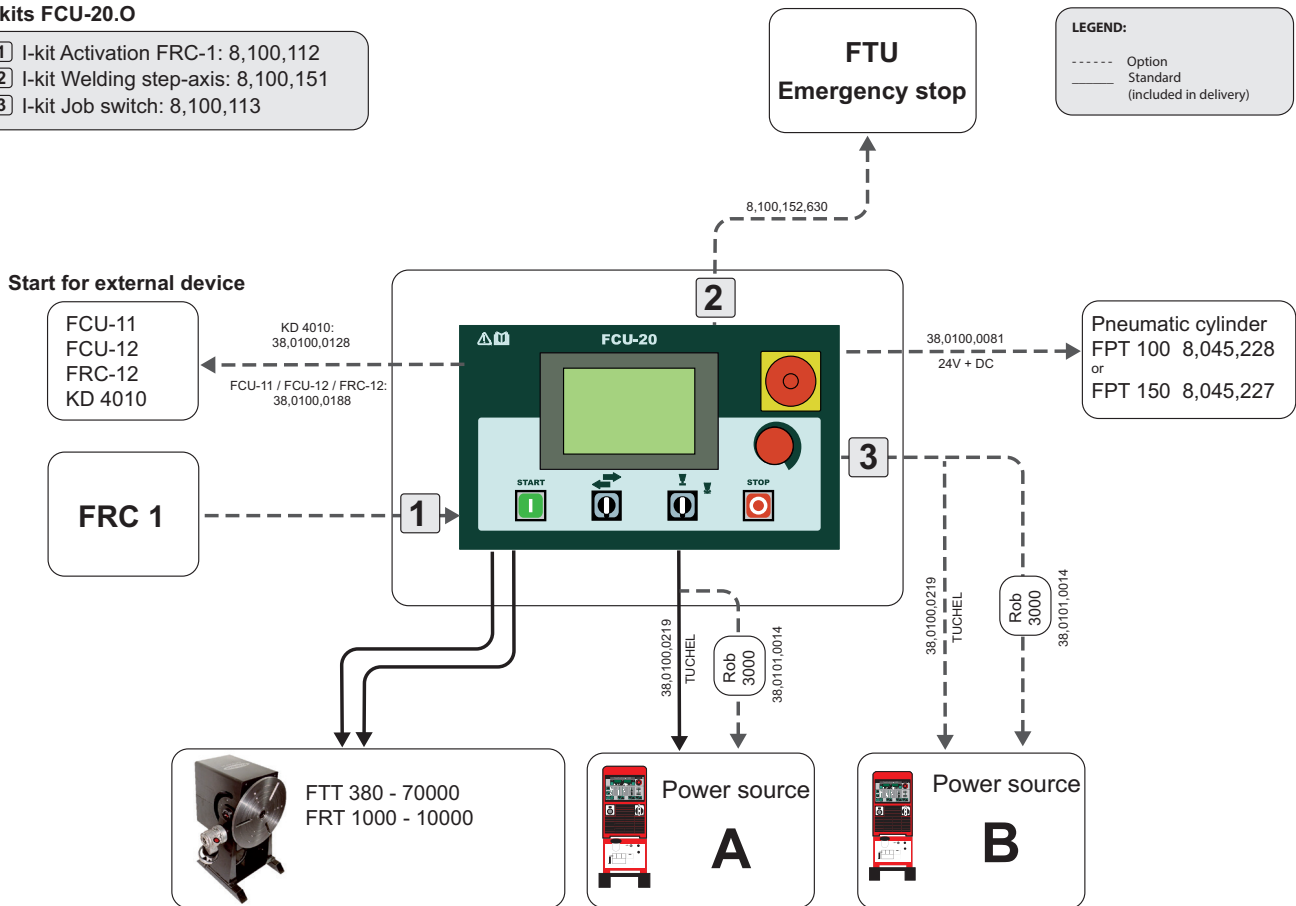

### Installation kit

- I-kit, start/stop A/B or A and B (for 2 welding power sources), (factory installation).  
Item number: 8,100,113
- I-kit, controller for FRC-1 pedal remote control (factory installation).  
Item number: 8,100,112
- I-kit, FCU offset axis (only in conjunction with FTU tripod unit and FTU offset axis I-kit 8,100,152,630).  
Item number: 8,100,151

### Pedal remote control

- FRC-1 with 3 m cable and protection.  
Item number: 8,045,011

### Connecting lead

- Connecting lead 5 m, FCU-20 to FPT (pneumatic torch positioning).  
Item number: 38,0100,0081
- Connecting lead 5 m, FCU-20 to FCU-11, FCU-12.  
Item number: 38,0100,0188
- Connecting lead 3 m, FCU-20 to KD-4010.  
Item number: 38,0100,0128

# EU Declaration of conformity FCU20



**EU-KONFORMITÄTSERKLÄRUNG 2016**  
**EU-DECLARATION OF CONFORMITY 2016**  
**DÉCLARATION UE DE CONFORMITÉ, 2016**

Wels-Thalheim, 2016-04-20

Die Firma

Manufacturer

La compagnie

**FRONIUS INTERNATIONAL GMBH**

Froniusplatz 1, 4600 Wels

erklärt in alleiniger Verantwortung,  
dass folgendes Produkt:

Hereby certifies on its sole  
responsibility that the following  
product:

se déclare seule responsable du fait  
que le produit suivant:

FCU 20  
Steuergerät

FCU 20  
Control unit

FCU 20  
Appareil de commande

auf das sich diese Erklärung  
bezieht, mit folgenden Richtlinien  
bzw. Normen übereinstimmt:

which is explicitly referred to by this  
Declaration meet the following  
directives and standard(s):

qui est l'objet de la présente  
déclaration correspondent aux  
suivantes directives et normes:

Richtlinie 2014/35/EU  
Elektrische Betriebsmittel  
Niederspannungsrichtlinie

Directive 2014/35/EU  
Electrical Apparatus  
Low Voltage Directive

Directive 2014/35/UE  
Outillages électriques  
Directive de basse tension

Richtlinie 2014/30/EU  
Elektromag. Verträglichkeit

Directive 2014/30/EU  
Electromag. compatibility

Directive 2014/30/UE  
Électromag. Compatibilité

Richtlinie 2011/65/EU  
RoHS

Directive 2011/65/EU  
RoHS

Directive 2011/65/UE  
RoHS

Europäische Normen inklusive  
zutreffende Änderungen  
EN ISO 12100:2010  
EN 60204-1:2006 (18.3 -18.7)  
EN 61000-6-2:2005  
EN 61000-6-4:2007

European Standards including  
relevant amendments  
EN ISO 12100:2010  
EN 60204-1:2006 (18.3 -18.7)  
EN 61000-6-2:2005  
EN 61000-6-4:2007

Normes européennes avec  
amendements correspondants  
EN ISO 12100:2010  
EN 60204-1:2006 (18.3 -18.7)  
EN 61000-6-2:2005  
EN 61000-6-4:2007

Die oben genannte Firma hält  
Dokumentationen als Nachweis der  
Erfüllung der Sicherheitsziele und  
die wesentlichen Schutzanforder-  
ungen zur Einsicht bereit.

Documentation evidencing  
conformity with the requirements of  
the Directives is kept available for  
inspection at the above  
Manufacturer.

En tant que preuve de la satisfaction  
des demandes de sécurité la  
documentation peut être consultée  
chez la compagnie susmentionnée.

Dokumentationsverantwortlicher:  
(technische Dokumentation)

person responsible for documents:  
(technical documents)

responsible documentation:  
(technique documentation)

Ing. Josef Feichtinger  
Günter Fronius Straße 1  
A - 4600 Wels-Thalheim

Ing. Josef Feichtinger  
Günter Fronius Straße 1  
A - 4600 Wels-Thalheim

Ing. Josef Feichtinger  
Günter Fronius Straße 1  
A - 4600 Wels-Thalheim

**CE 2016**

ppa. Mag. Ing. H. Hackl  
Member of Board  
Chief Technology Officer

# EU Declaration of conformity FCU20.O



**EU-KONFORMITÄTSERKLÄRUNG 2016  
EU-DECLARATION OF CONFORMITY 2016  
DÉCLARATION UE DE CONFORMITÉ, 2016**

Wels-Thalheim, 2016-04-20

Die Firma

Manufacturer

La compagnie

**FRONIUS INTERNATIONAL GMBH**

Froniusplatz 1, 4600 Wels

erklärt in alleiniger Verantwortung,  
dass folgendes Produkt:

Hereby certifies on its sole  
responsibility that the following  
product:

se déclare seule responsable du fait  
que le produit suivant:

FCU 20.O  
Steuergerät

FCU 20.O  
Control unit

FCU 20.O  
Appareil de commande

auf das sich diese Erklärung  
bezieht, mit folgenden Richtlinien  
bzw. Normen übereinstimmt:

which is explicitly referred to by this  
Declaration meet the following  
directives and standard(s):

qui est l'objet de la présente  
déclaration correspondent aux  
suivantes directives et normes:

Richtlinie 2014/35/EU  
Elektrische Betriebsmittel  
Niederspannungsrichtlinie

Directive 2014/35/EU  
Electrical Apparatus  
Low Voltage Directive

Directive 2014/35/UE  
Outillages électriques  
Directive de basse tension

Richtlinie 2014/30/EU  
Elektromag. Verträglichkeit

Directive 2014/30/EU  
Electromag. compatibility

Directive 2014/30/UE  
Électromag. Compatibilité

Richtlinie 2011/65/EU  
RoHS

Directive 2011/65/EU  
RoHS

Directive 2011/65/UE  
RoHS

Europäische Normen inklusive  
zutreffende Änderungen  
EN ISO 12100:2010  
EN 60204-1:2006 (18.3 -18.7)  
EN 61000-6-2:2005  
EN 61000-6-4:2007

European Standards including  
relevant amendments  
EN ISO 12100:2010  
EN 60204-1:2006 (18.3 -18.7)  
EN 61000-6-2:2005  
EN 61000-6-4:2007

Normes européennes avec  
amendements correspondants  
EN ISO 12100:2010  
EN 60204-1:2006 (18.3 -18.7)  
EN 61000-6-2:2005  
EN 61000-6-4:2007

Die oben genannte Firma hält  
Dokumentationen als Nachweis der  
Erfüllung der Sicherheitsziele und  
die wesentlichen Schutzanforder-  
ungen zur Einsicht bereit.

Documentation evidencing  
conformity with the requirements of  
the Directives is kept available for  
inspection at the above  
Manufacturer.

En tant que preuve de la satisfaction  
des demandes de sécurité la  
documentation peut être consultée  
chez la compagnie susmentionnée.

Dokumentationsverantwortlicher:  
(technische Dokumentation)

person responsible for documents:  
(technical documents)

responsible documentation:  
(technique documentation)

Ing. Josef Feichtinger  
Günter Fronius Straße 1  
A - 4600 Wels-Thalheim

Ing. Josef Feichtinger  
Günter Fronius Straße 1  
A - 4600 Wels-Thalheim

Ing. Josef Feichtinger  
Günter Fronius Straße 1  
A - 4600 Wels-Thalheim

**CE 2016**

*ppa Hackl*  
ppa. Mag. Ing. H. Hackl

Member of Board  
Chief Technology Officer

DE German

Deutsch

EN English

English

FR French

Française

## Circuit diagrams

- FCU-20
- FCU-20.O

Project : 8,040,073\_FCU-20FX3G  
 Order : 8,040,073  
 Customer : Referenz  
 Drawn by : NH  
 Date : 10.12.2015  
 CAD Version : AutoCad escad 2010 V7.0.33.0

Only qualified personnel is authorized to install, start up, repair or service the units.  
 Perform electrical installation according to the pertinent regulations (e.g. line cross sections, fusing, protective conductor connection).

wiring colours

mains voltage : schwarz  
 N : blau  
 PE : ge/gn  
 Control voltage AC : grau  
 Control voltage DC : grau  
 External voltage : grau  
 analogue voltage : grau

Power supply connection :  
 PE  
 PE+N  
 PEN  
 Control voltage :  
 Transformer  
 Transformer + Rectifier  
 directly picked off



Revision	Sheet	Name	Date	Name	Description	Order	Customer	Referenz	Sheet	Sh.
a			10.12.2015	NH	FCU-20				17	
b		Drawer Assembly	10.02.2011	GK		8,040,073				
c		Project Leader	20.02.2011	PA						
d										
					COVER	+				

1 2 3 4 5 6 7 8

Standard  
Option

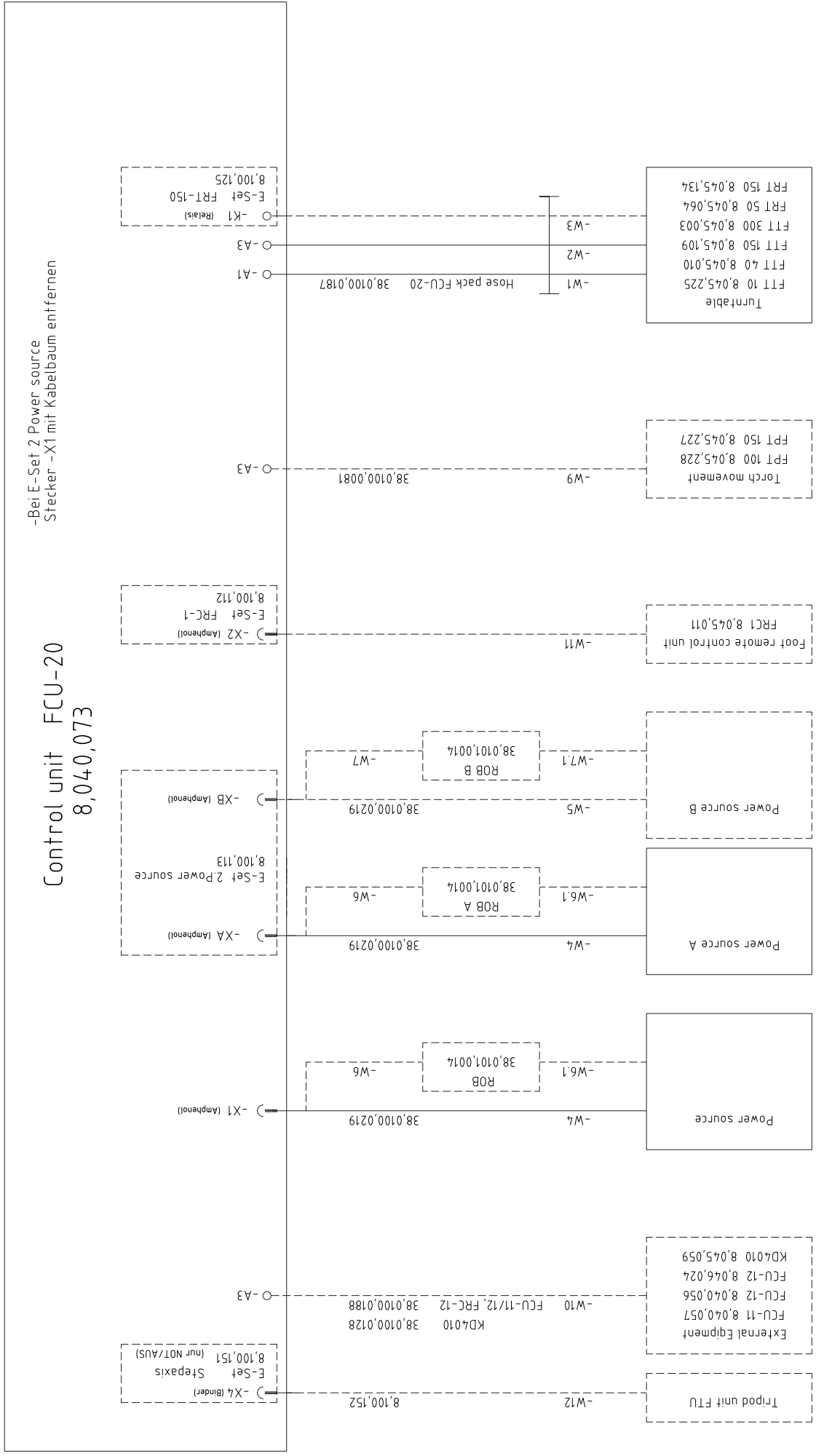

Revision	Date	Name	Drawer	Date	Name	Overview FCU-20			Description	Order	Customer	Referenz	Sheet	16	Sh.
a			Assembly	10.12.2015	NH	Frönius			FCU-20				1		
b			Project Leader	10.02.2011	GK										
c				20.02.2011	PA										
d															

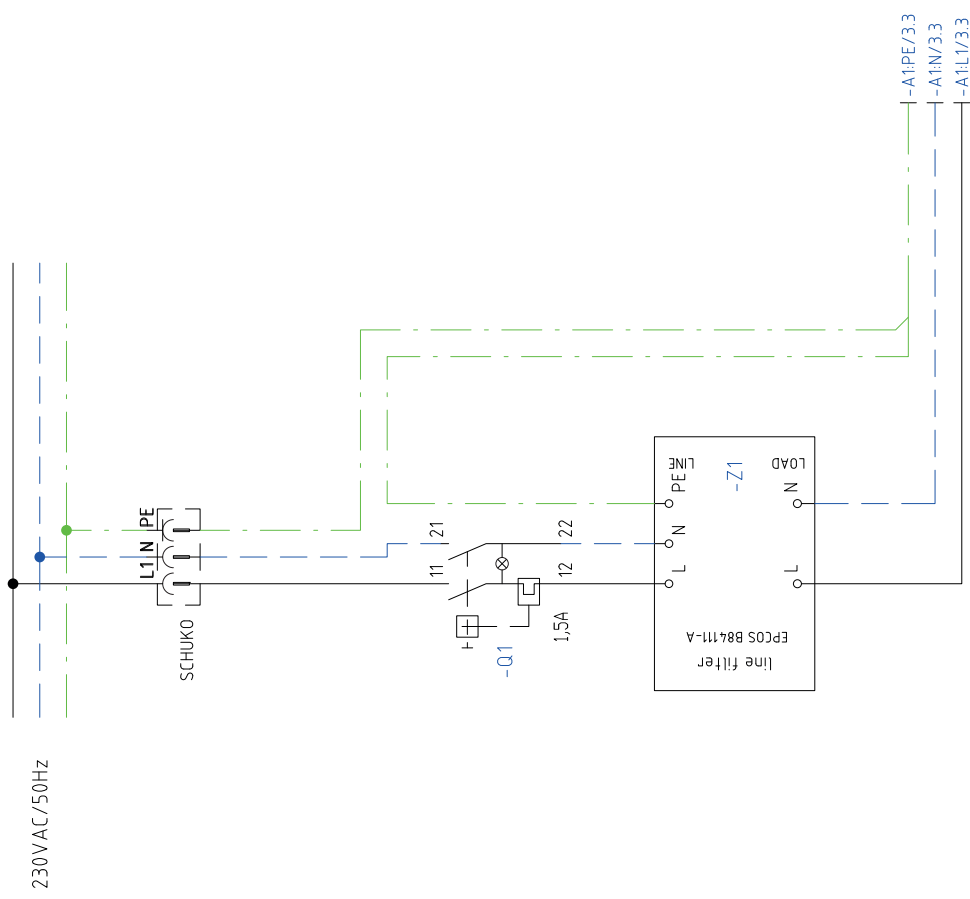

Revision	Date	Name	Date	Name	Description	
a			10.12.2015	NH	FCU-20	
b		Drawer	10.02.2011	GK	Order	8,040,073
c		Assembly			Customer	Referenz
d		Project Leader	20.02.2011	PA		

  

= 1	
+ 1	
Sheet	2
16	Sh.

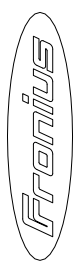

Power supply



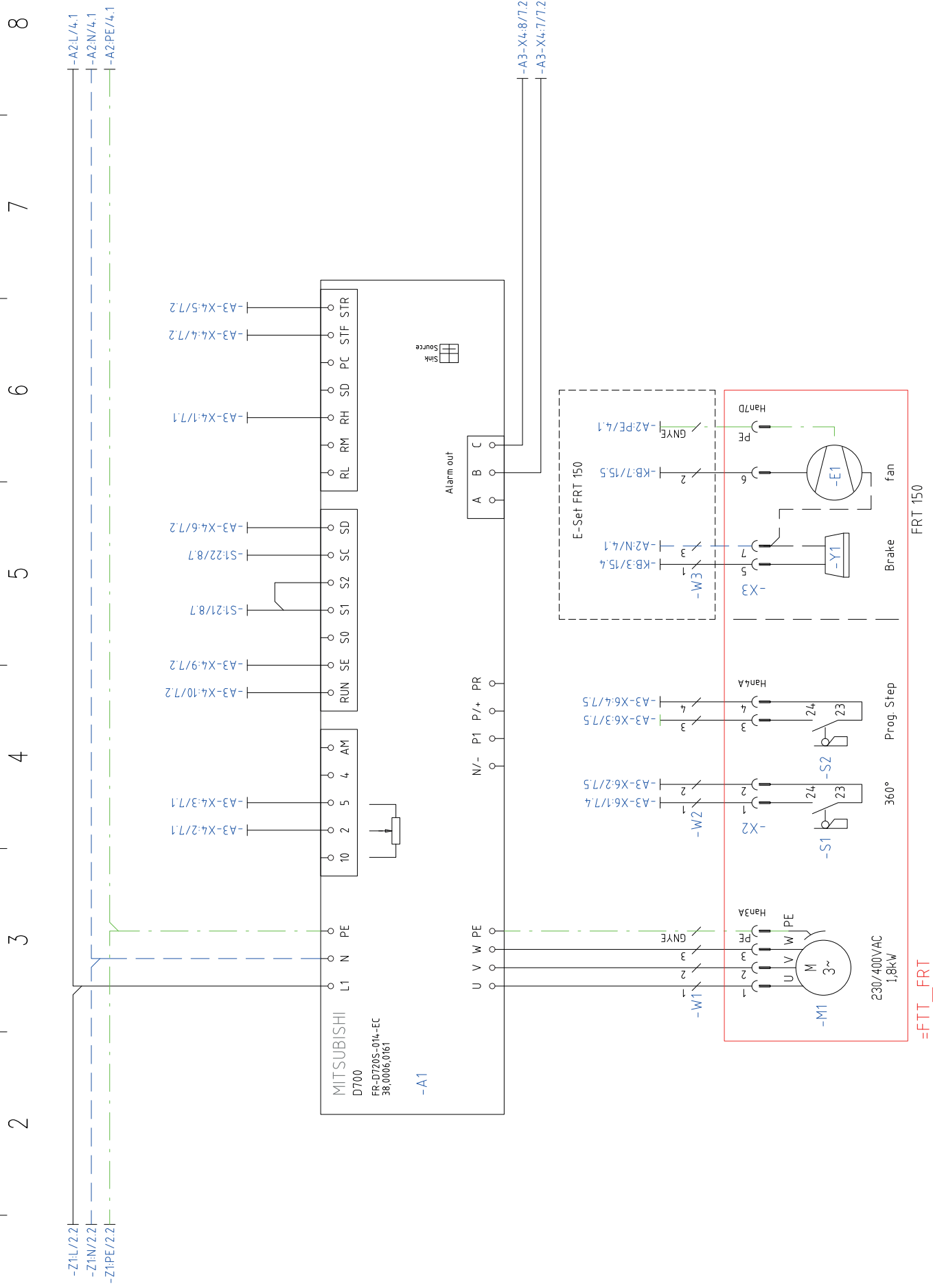

=FTT\_FRT

Revision	Date	Name	Date	Name	Frequency converter		Description
a							FCU-20
b							Order
c							Customer
d							Referenz
							8,040,073
							Sheet 3
							16
							Sh.

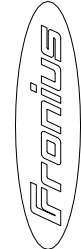

Frequency converter

FCU-20

Order

Sheet 3

16

Sh.

All rights reserved, in particular the rights of duplication and distribution.

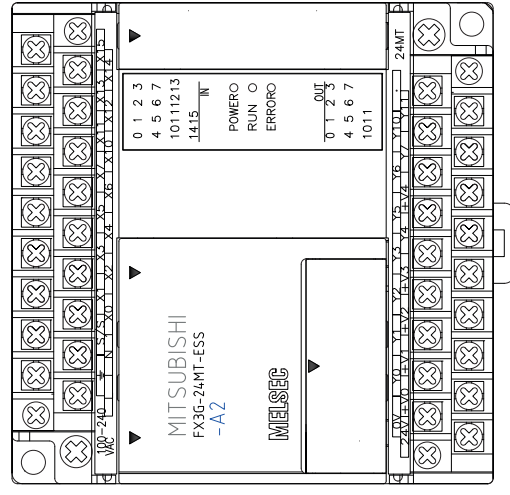
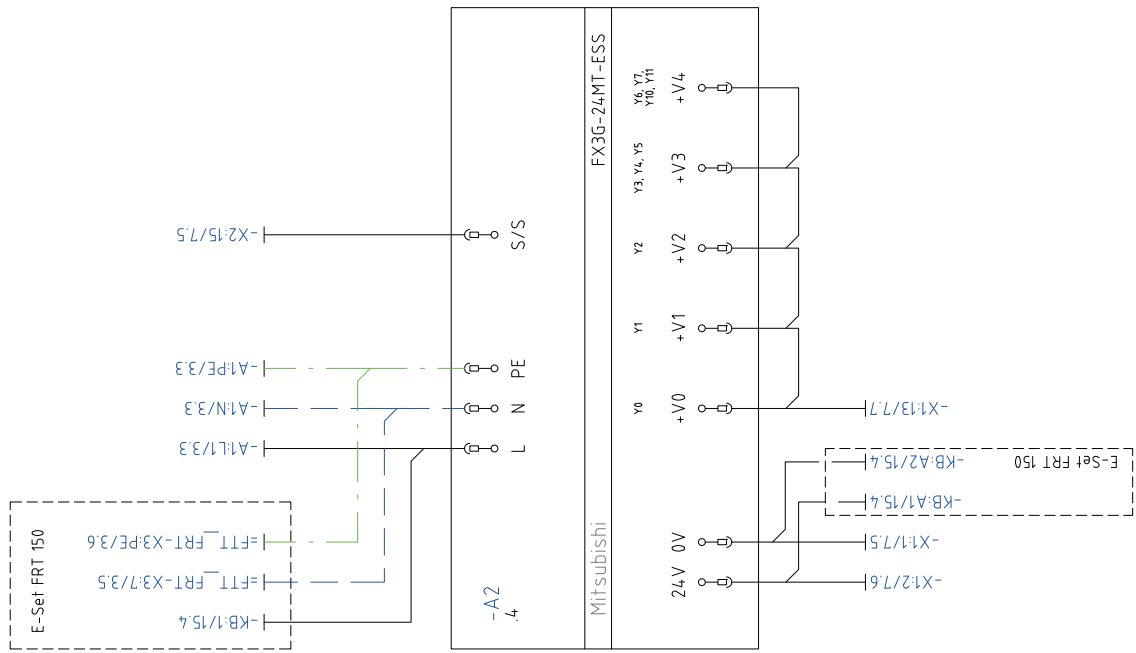

X0 /5.1	X7 /5.7	Y5 /6.5
X1 /5.2	X10 /5.1	Y6 /6.6
X2 /5.3	X11 /5.2	Y7 /6.7
X3 /5.4	X12 /5.3	Y10 /6.1
X4 /5.4	X13 /5.4	Y11 /6.2
X5 /5.5	X14 /5.4	
X6 /5.6	X15 /5.5	

Revision	Date	Name	Date	Name	PLC Power supply		Description	FCU-20	= 1
a			10.12.2015	NH			Order	8,040,073	+ 1
b			10.02.2011	GK			Customer	Referenz	
c			20.02.2011	PA					
d									
								Sheet	4
								16	Sh.



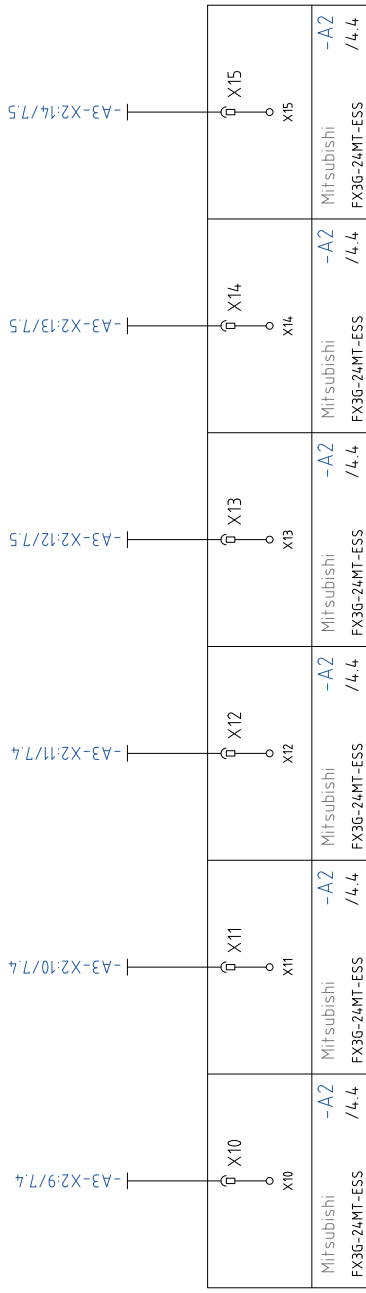
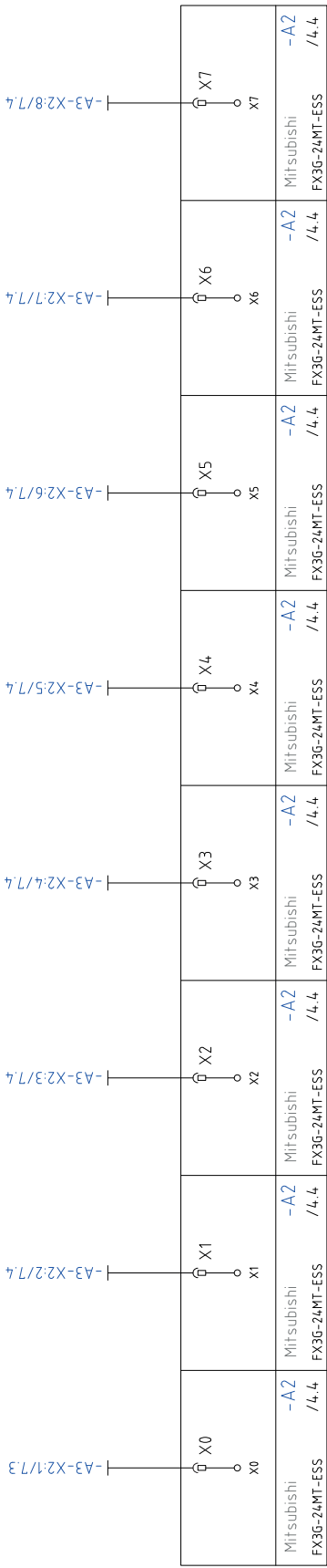

Revision	Date	Name	Date	Name	PLC Inputs		Description	Order	Customer	Referenz	Sheet	Sh.
a			10.12.2015	NH			FCU-20	+ 1			5	
b		Drawer	10.02.2011	GK							16	
c		Assembly										
d		Project Leader	20.02.2011	PA								

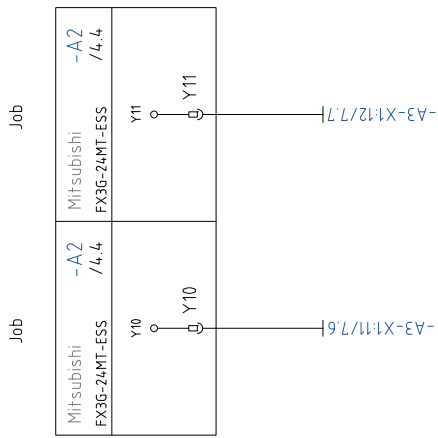
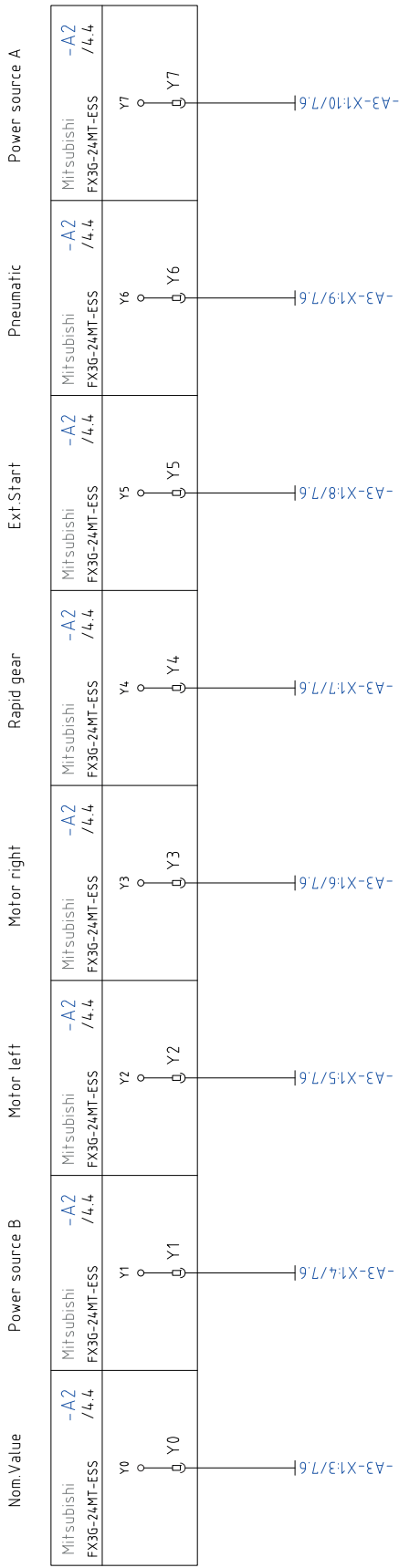

Revision	Date	Name	Date	Name	PLC Outputs		Description
a			10.12.2015	NH			FCU-20
b		Drawer	10.02.2011	GK			Order
c		Assembly	20.02.2011	PA			8,040,073
d		Project Leader			Customer		Referenz
					= 1		
					+ 1		
					Sheet 6		
					16		Sh.



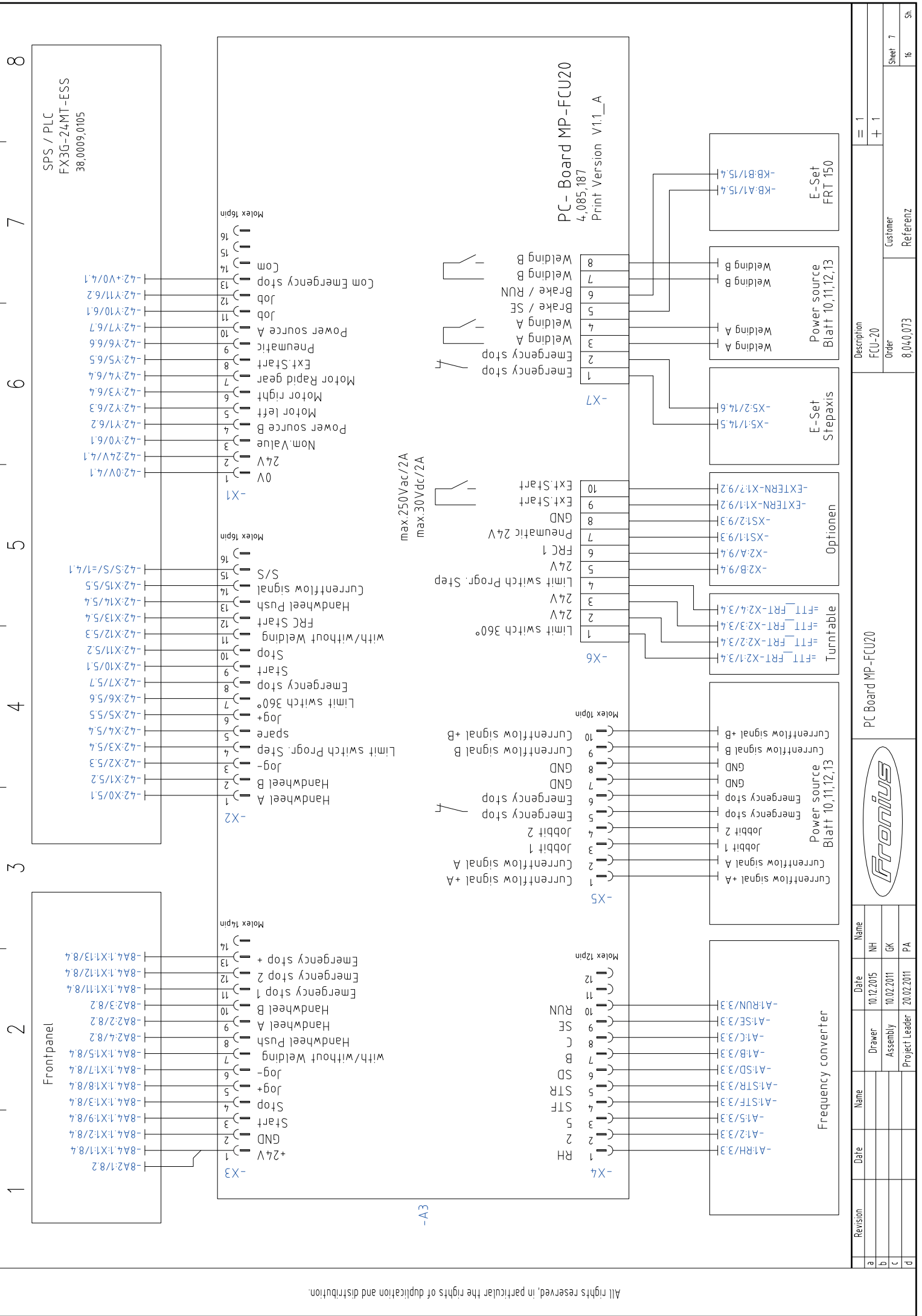

Revision	Date	Name	Date	Name
a	10.12.2015	NH		
b	10.02.2011	GK		
c				
d	20.02.2011	PA		

Project Leader		Assembly		Drawer	
20.02.2011		10.02.2011		NH	

Customer		Description	
Referenz		FCU-20	
8,04,0,073		+ 1	
		= 1	

Sheet 7	16	Sh.
---------	----	-----



PC Board MP-FCU20

PC- Board MP-FCU20  
4,085,187  
Print Version V1.1\_A

1 2 3 4 5 6 7 8

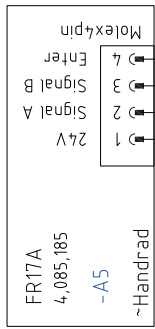

-A3-X3:1/7.1  
-A3-X3:9/7.2  
-A3-X3:10/7.2  
-A3-X3:8/7.2

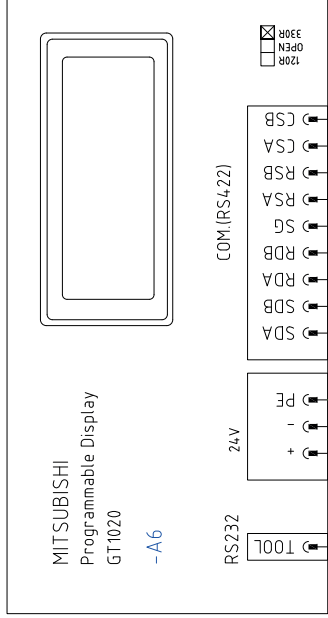

COM (RS4.22)

RS232

24V

TOOL

PE

+

-

BN

RD

SDB

SDA

RDB

SG

RSA

RSA

CSA

CSB

120R

OPEN

300R

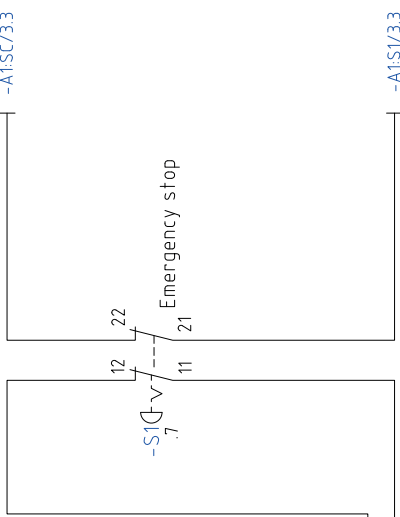

RS422 Cable

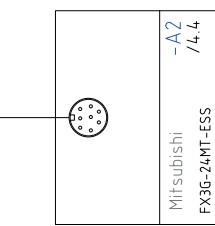

-A4  
TP FCU/ FRC  
4,085,184

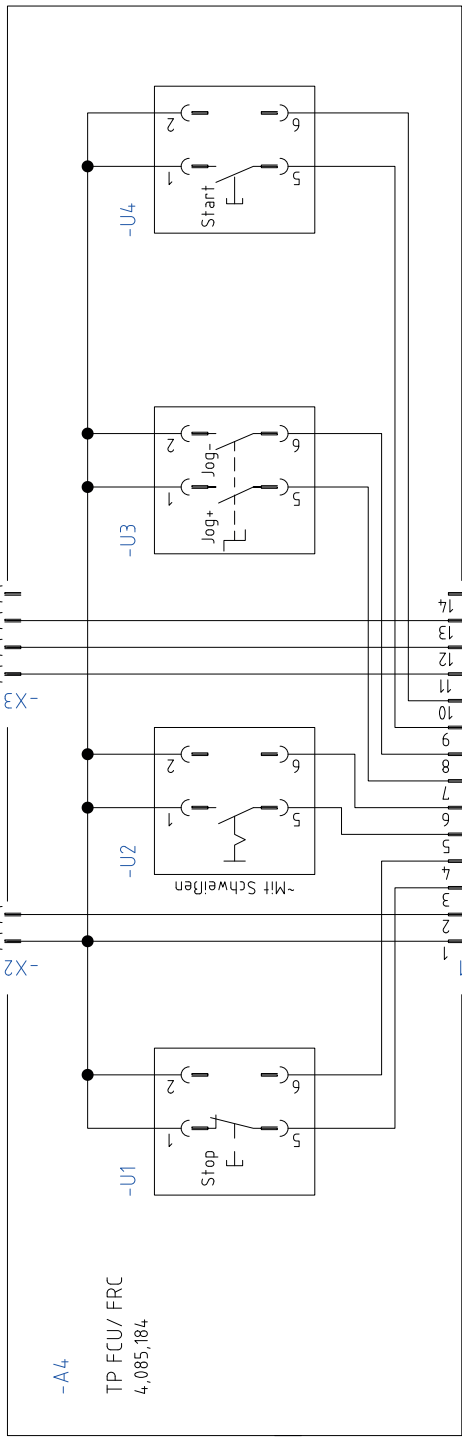

-A3-X3:1/7.1  
-A3-X3:2/7.1  
-A3-X3:4/7.2  
-A3-X3:7/7.2  
-A3-X3:6/7.2  
-A3-X3:5/7.2  
-A3-X3:3/7.1  
-A3-X3:11/7.2  
-A3-X3:12/7.2  
-A3-X3:13/7.2

Revision	Date	Name	Date	Name	Frontpanel FCU-20		
a			10.12.2015	NH	Description	FCU-20	= 1
b		Drawer	10.02.2011	GK	Order	8,040,073	+ 1
c		Assembly	20.02.2011	PA	Customer	Referenz	Sheet 8
d		Project Leader					16
							Sh.



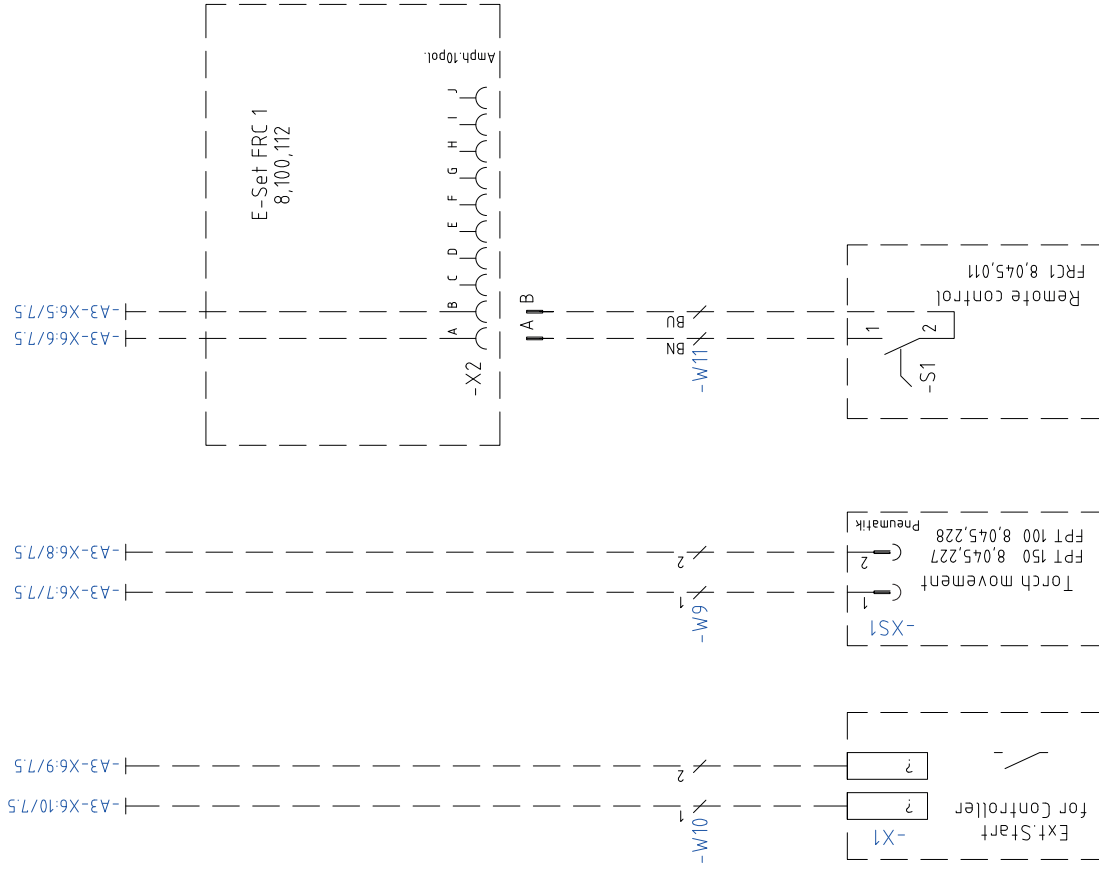

Revision	Date	Name	Date	Name	Optionen		Description	Order	Customer	Sheet	Sh.
a			10.12.2015	NH			FRCU-20	+ 1		9	
b			10.02.2011	GK					Referenz	16	
c											
d			20.02.2011	PA							



1 2 3 4 5 6 7 8

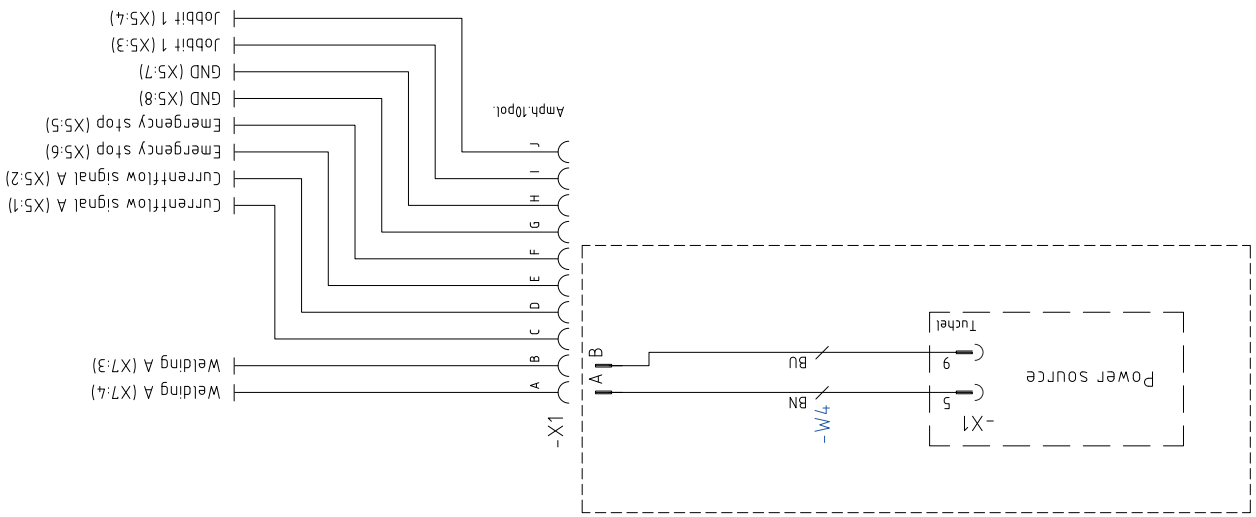

Revision	Date	Name	Date	Name	Description	Order	Customer	Sheet	Sh.
a			10.12.2015	NH	FCU-20			10	
b		Assembly	10.02.2011	GK			Referenz	16	
c		Project Leader	20.02.2011	PA		8,040,073			
d									



Power source Control Tuchel  
Standardversion

38,0100,0219



1 2 3 4 5 6 7 8

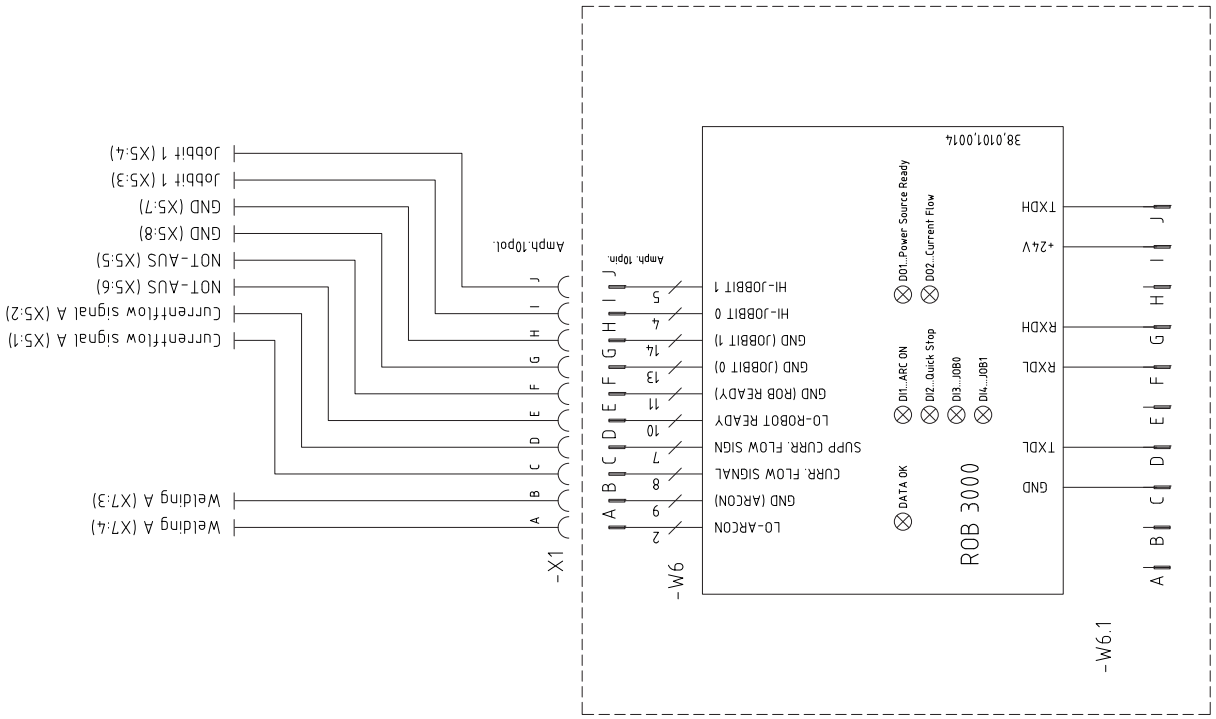

Rob 3000 38,0101,0014

Revision	Date	Name	Date	Name	Description	Order	Customer	Sheet	Sh.	
a			10.12.2015	NH	FCU-20			11		
b		Drawer	10.02.2011	GK				16		
c		Assembly								
d		Project Leader	20.02.2011	PA		8,040,073	Referenz			
					Power source Control A ROB-3000					



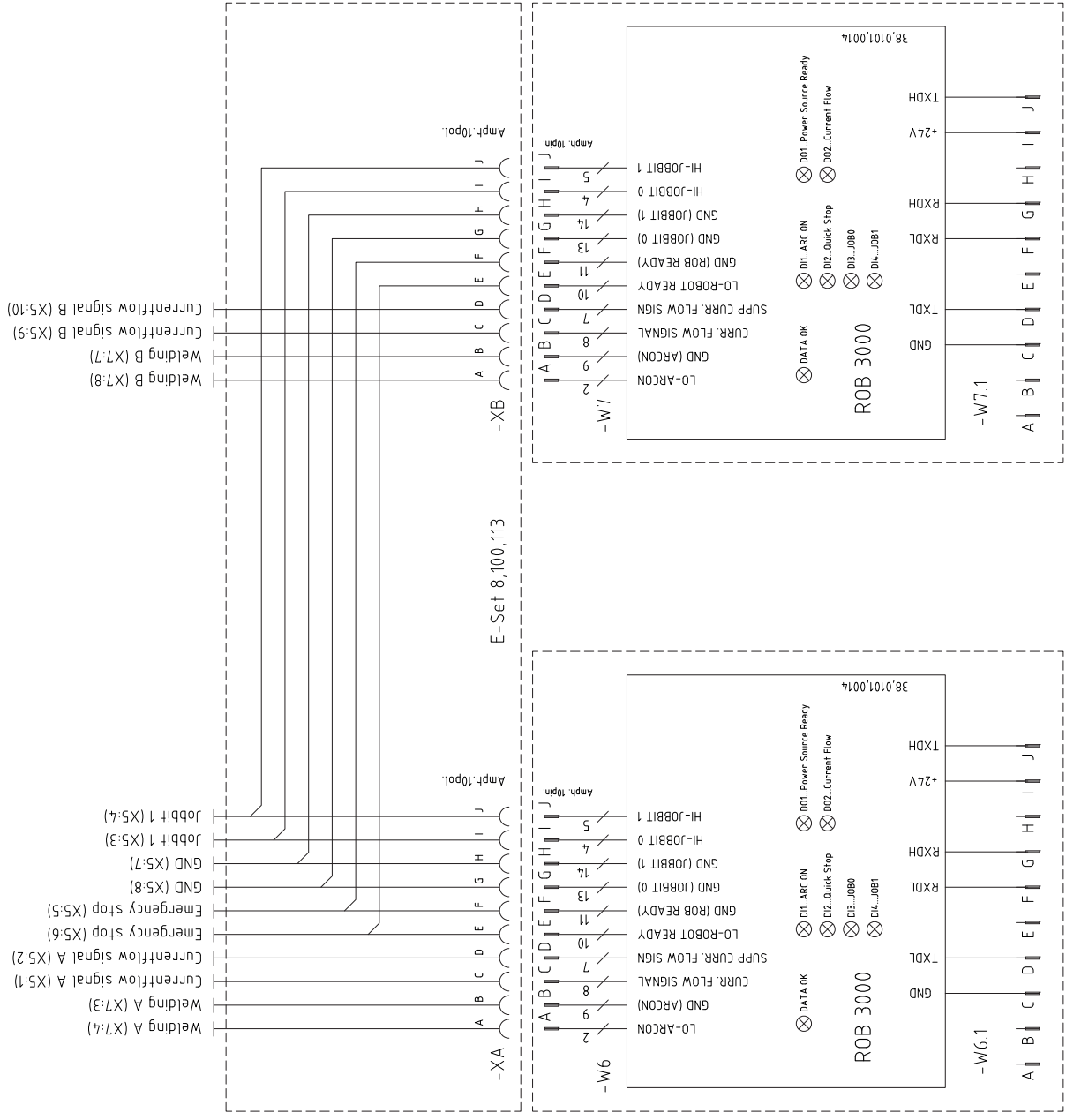

Revision	Date	Name	Date	Name	Description
a			10.12.2015	NH	FCU-20
b		Assembly	10.02.2011	GK	Order
c		Project Leader	20.02.2011	PA	Customer
d					Referenz

8,04,0,073	8,04,0,073
+ 1	+ 1
Sheet 12	Sh.



Power source Control A/B ROB-3000

38,0101,0014

38,0101,0014

1 2 3 4 5 6 7 8

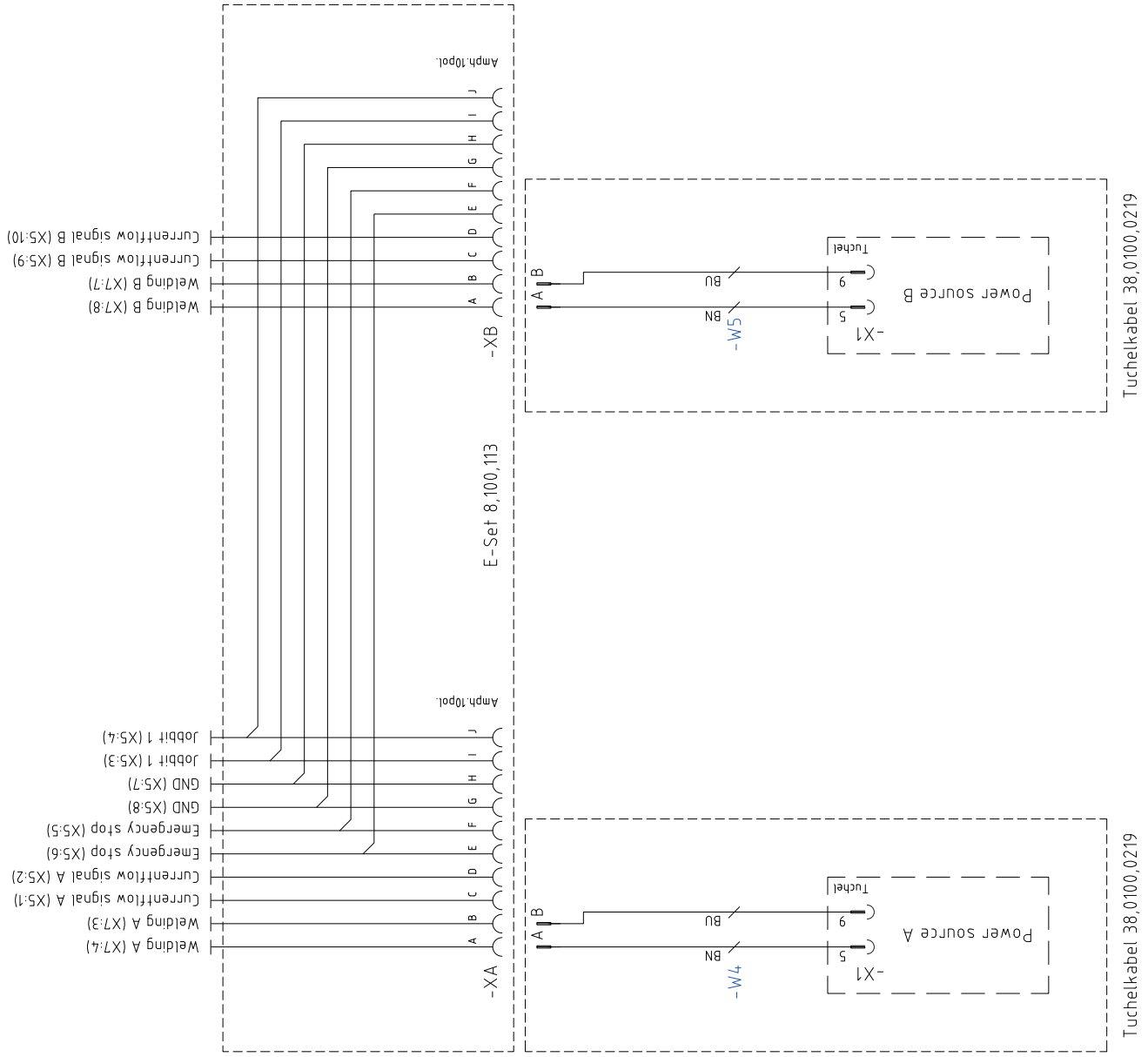

Revision	Date	Name	Date	Name	Description	Order	Customer	Referenz	Sheet	13	16	Sh.
a			10.12.2015	NH	Power source Control A/B Tuchel							
b			10.02.2011	GK								
c			20.02.2011	PA								
d												



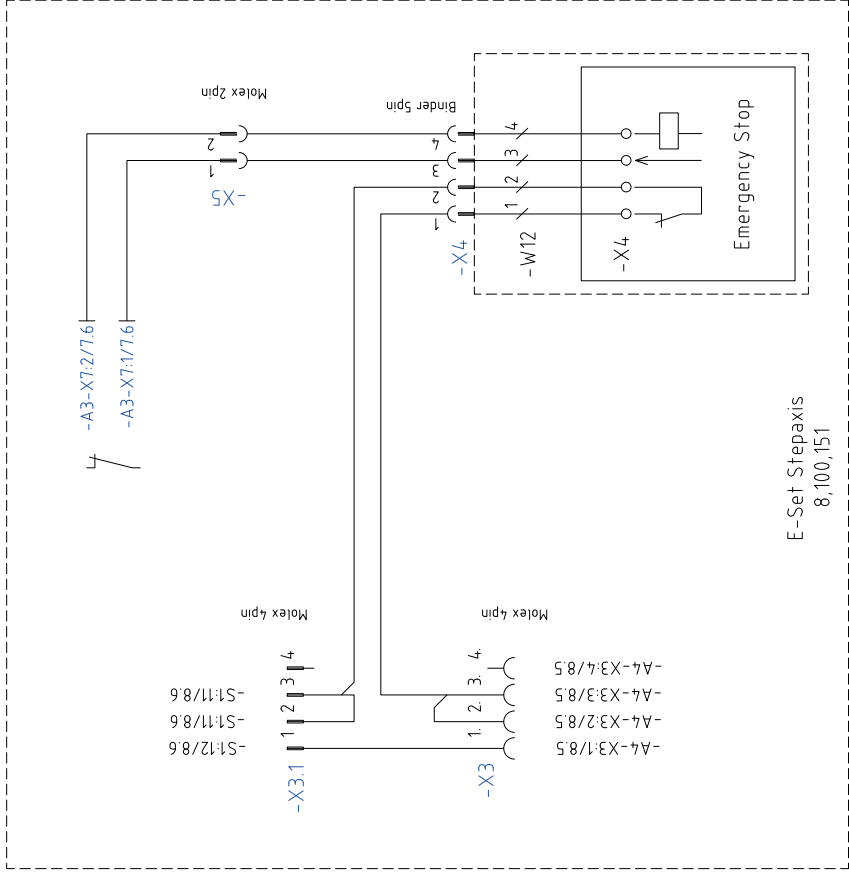

All rights reserved, in particular the rights of duplication and distribution.

Revision	Date	Name	Date	Name	Description	Order	Customer	Sheet	It.	Sh.
a			10.12.2015	NH	FCU-20	+ 1				
b		Drawer	10.02.2011	GK						
c		Assembly								
d		Project Leader	20.02.2011	PA						
E-Set Stepaxis Emergency-Stop						8,040,073	Referenz			



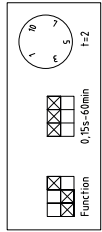
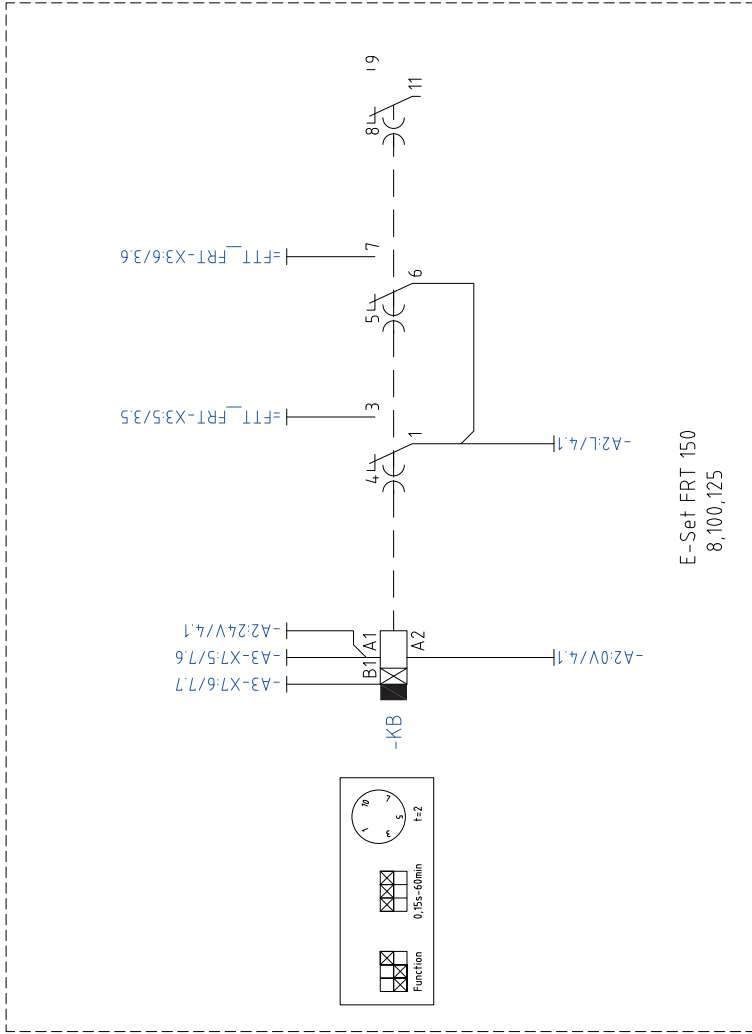

Revision	Date	Name	Date	Name	Description	Order	Customer	Sheet	Sh.
a			10.12.2015	NH	FCTU-20	+ 1		15	
b		Drawer	10.02.2011	GK				16	
c		Assembly							
d		Project Leader	20.02.2011	PA					
					E-Set FRT 150	8,040,073	Referenz		

# Hose pack FCU 20 / 50

## Kabel 38cm

Kabel 32cm

Han 3A  
Buchse

- =1/3.3/=1+1-A1:U
- =1/3.3/=1+1-A1:V
- =1/3.3/=1+1-A1:W
- =1/3.3/=1+1-A1:PE

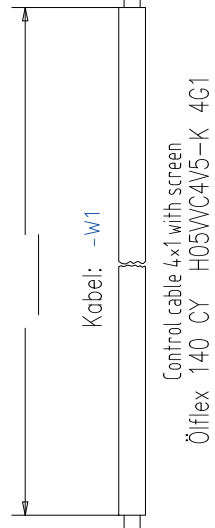

FCU 20

FCU 50

- =1/3.3/=FTT\_FRT-X1:1
- =1/3.3/=FTT\_FRT-X1:2
- =1/3.3/=FTT\_FRT-X1:3
- =1/3.3/=FTT\_FRT-X1:PE

- U1:U
- U1:V
- U1:W
- U1:PE

Han 4A  
Buchse

- =1/7.4/=1+1-A3-X6:1
- =1/7.5/=1+1-A3-X6:2
- =1/7.5/=1+1-A3-X6:3
- =1/7.5/=1+1-A3-X6:4

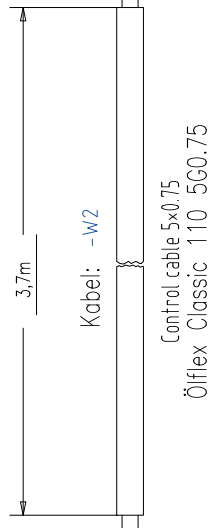

- =1/3.4/=FTT\_FRT+1-X2:1
- =1/3.4/=FTT\_FRT+1-X2:2
- =1/3.4/=FTT\_FRT+1-X2:3
- =1/3.4/=FTT\_FRT+1-X2:4

- A1-X12:1
- A1-X12:2
- N C
- N C

Hose 3m 22x1,5 SW

Revision	Date	Name	Date	Name
a			10.12.2015	NH
b		Drawer	10.02.2011	GK
c		Assembly		
d		Project Leader	20.02.2011	PA

Hose pack 38,0100,0187		Description FCU-20	
		Order 8,040,073	
		Customer Referenz	
		= 1	
		+ 1	
		Sheet 16	
		16	
		Sh.	

Project : 8,040,073,630\_FCU-20.0-FX3G\_GT10  
 Order : 8,040,073,630  
 Customer :  
 Drawn by : NH  
 Date : 07.02.11  
 CAD Version : AutoCad escad 2010 V7.0.33.0

Only qualified personnel is authorized to install, start up, repair or service the units.  
 Perform electrical installation according to the pertinent regulations (e.g. line cross sections, fusing, protective conductor connection).

wiring colours

mains voltage : black  
 N : blue  
 PE : yellow/green  
 Control voltage AC : grau  
 Control voltage DC : grau  
 External voltage : grau  
 analogue voltage : grau

Power supply connection :  
 PE  
 PE+N  
 PEN  
 Control voltage :  
 Transformer  
 Transformer + Rectifier  
 directly picked off



Revision	Sheet	Name	Date	Name	Description	COVER
a			07.02.11	NH	FCU-20.0	+
b		Drawer Assembly	12.02.11	GK	Order	
c		Project Leader	21.02.11	PA	8,040,073,630	
d					Customer	
						Sheet 1
						17

1 2 3 4 5 6 7 8

Standard  
Option

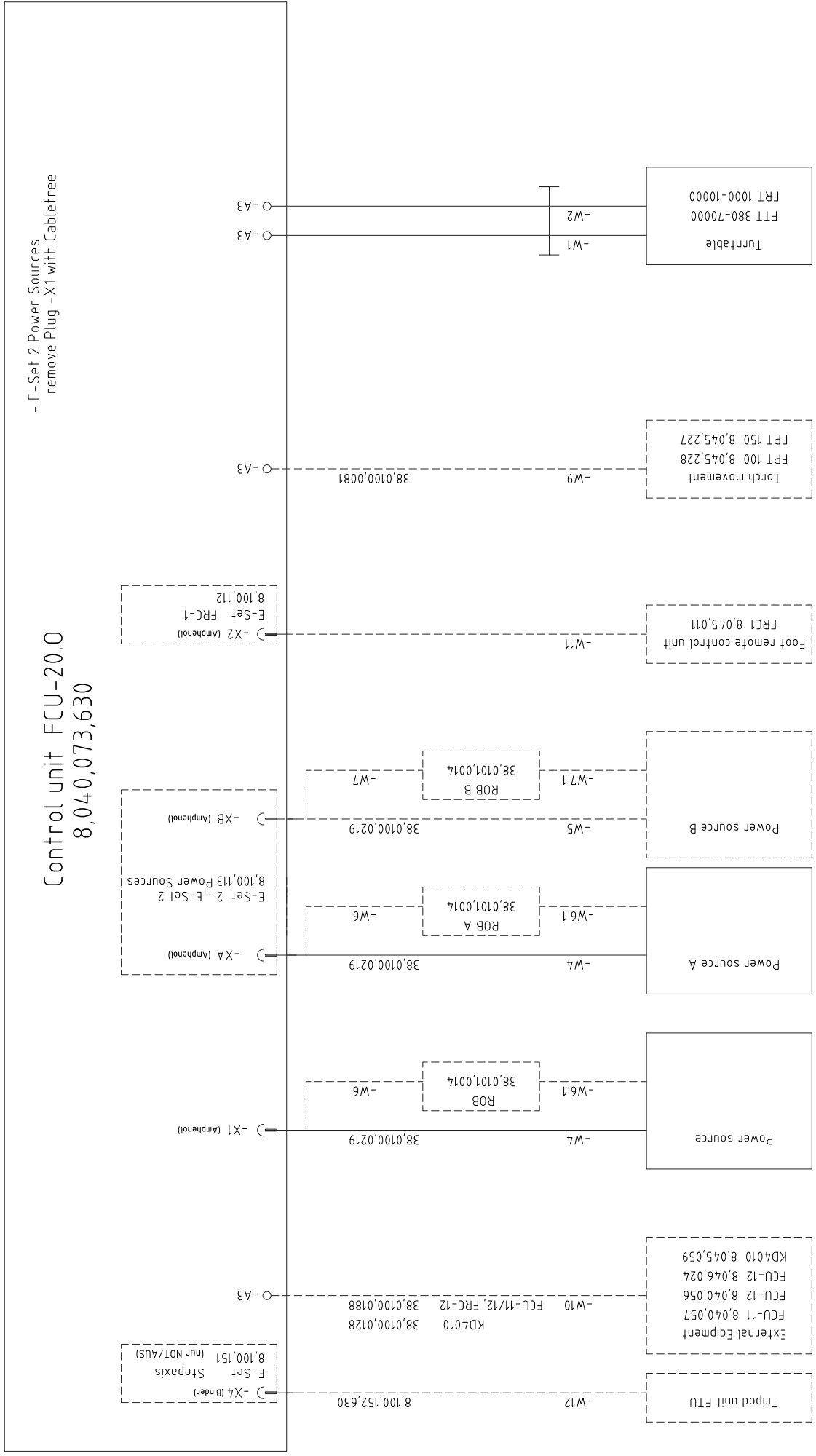

Revision	Date	Name	Date	Name	Overview FCU-20.0	
a					Description FCU-20.0	
b		Drawer	07.12.2015	NH	Order 8,040,073,630	
c		Assembly	12.02.11	GK	Customer	
d		Project Leader	21.02.11	PA	Sheet 1 16	



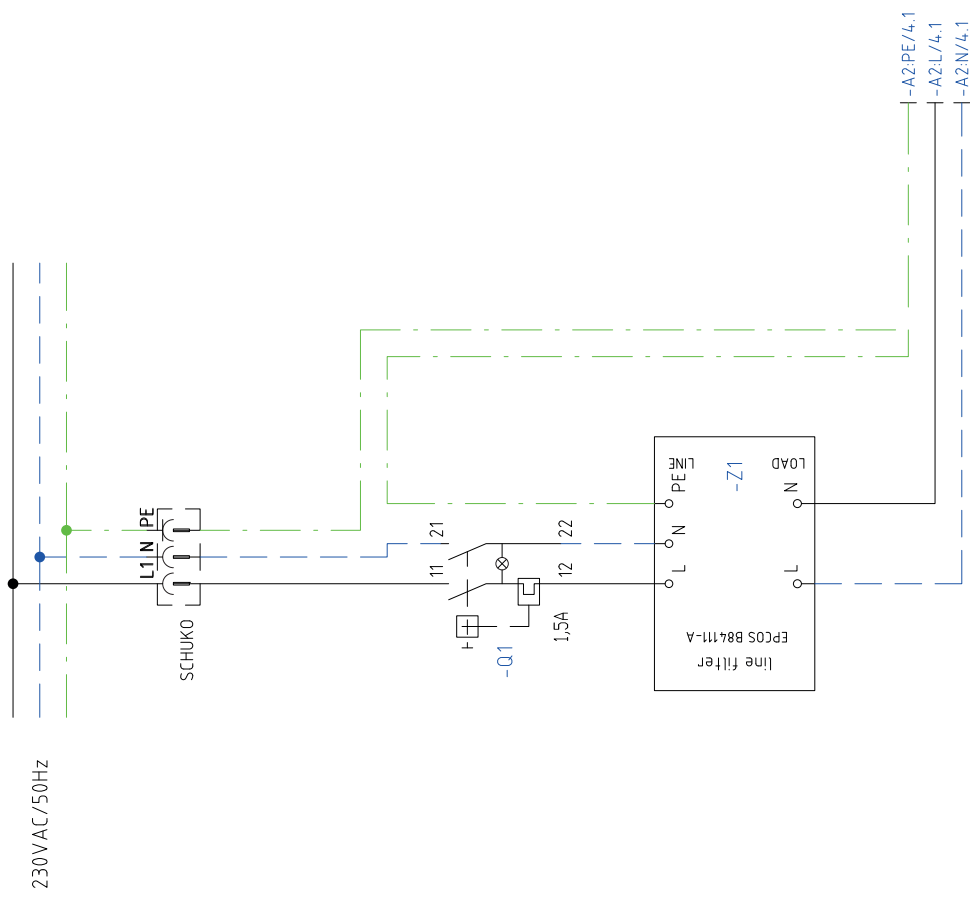

1 2 3 4 5 6 7 8

Revision	Date	Name	Date	Name	Description	
a			07.12.2015	NH	FCU-20.0	
b		Drawer	12.02.11	GK	Order	8,04,0,073,630
c		Assembly			Customer	
d		Project Leader	21.02.11	PA		

  

= 1	
+	
Sheet	2
16	Sh.



Power supply

1 2 3 4 5 6 7 8

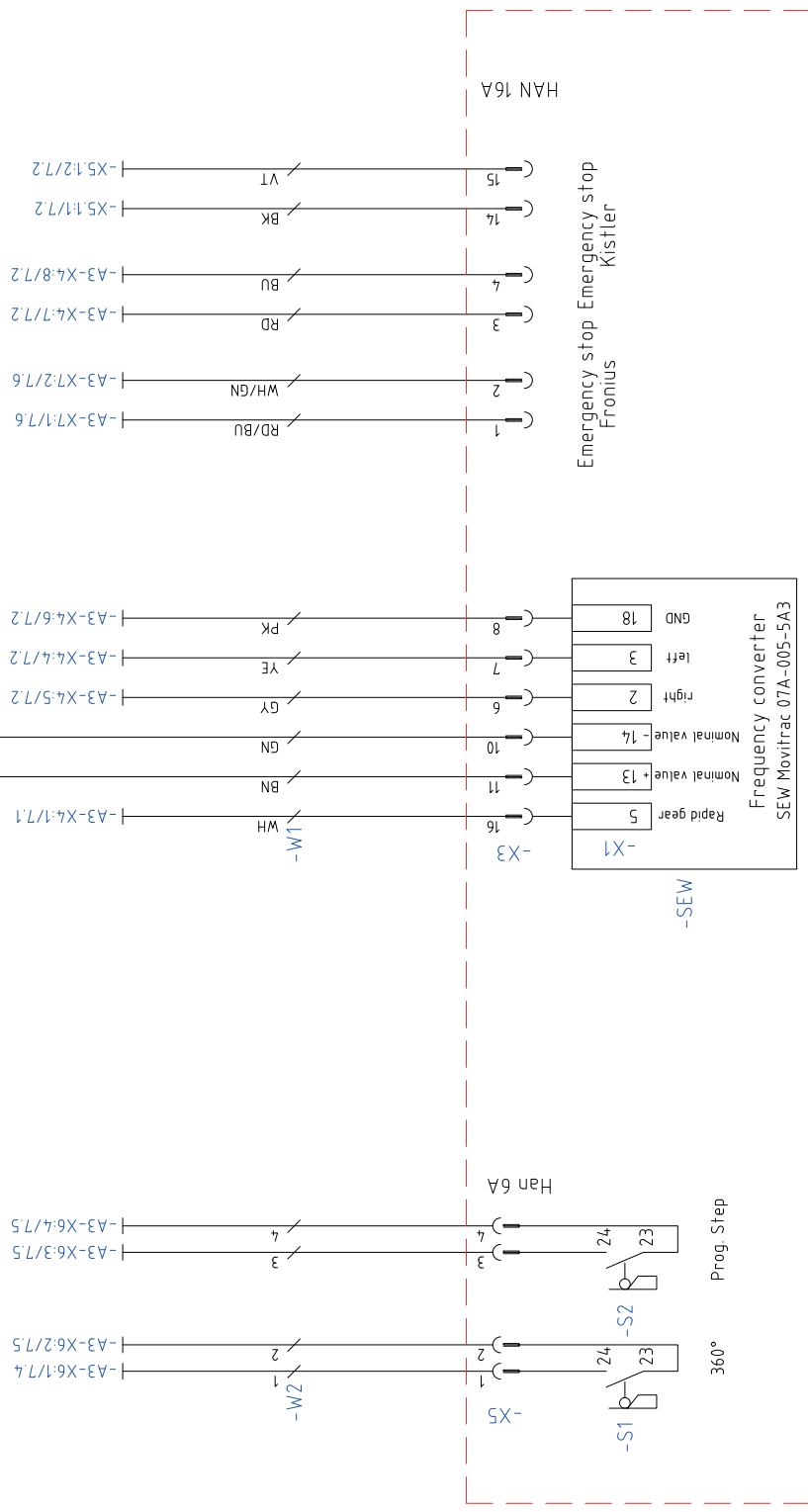
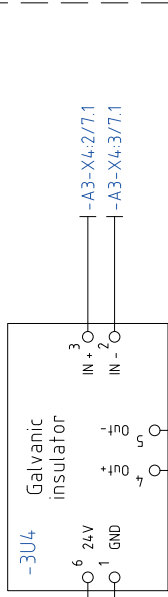

=FTT\_FRT

Revision	Date	Name	Date	Name	Kistler Connection		Description	= 1		
a			07.12.2015	NH			FCU-20.0	+		
b			12.02.11	GK			Order	Customer		
c							8,040,073,630			
d			21.02.11	PA						
							Sheet 3			
							16			
							Sh.			

All rights reserved, in particular the rights of duplication and distribution.

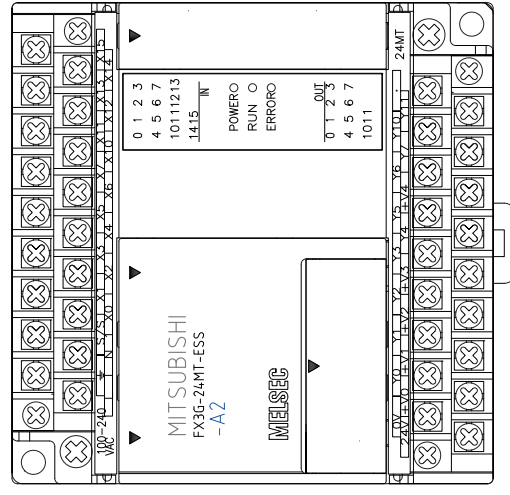
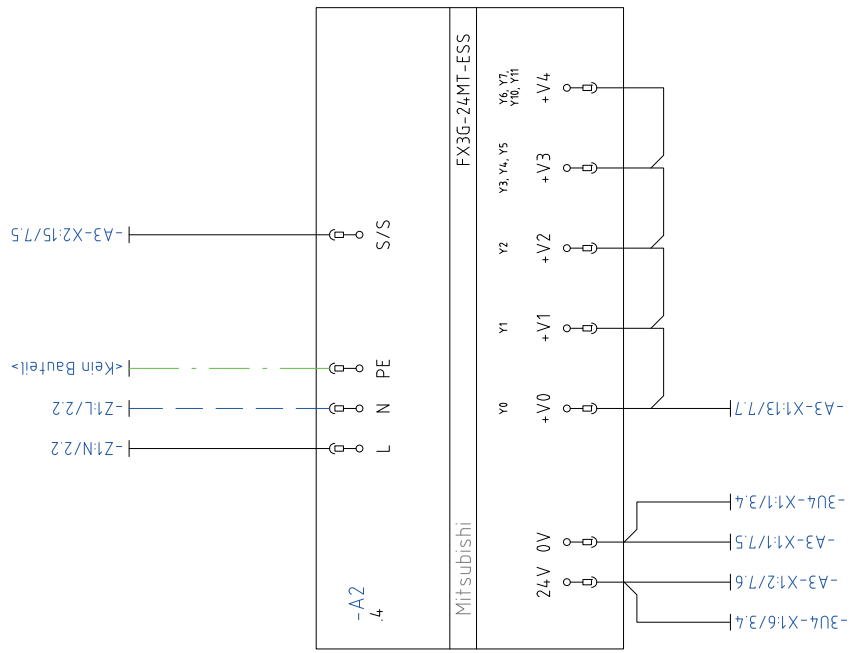

X0 /5.1	X7 /5.7	Y0 /6.1	Y5 /6.5
X1 /5.2	X10 /5.1	Y1 /6.2	Y6 /6.6
X2 /5.3	X11 /5.2	Y2 /6.3	Y7 /6.7
X3 /5.4	X12 /5.3	Y3 /6.4	Y10 /6.1
X4 /5.4	X13 /5.4	Y4 /6.4	Y11 /6.2
X5 /5.5	X14 /5.4		
X6 /5.6	X15 /5.5		

Revision	Date	Name	Date	Name	SPS Power supply		Description	= 1	
a			07.12.2015	NH			FCU-20.0	+	
b		Drawer	12.02.11	GK			Order		
c		Assembly	21.02.11	PA			Customer		
d		Project Leader			8,04,0,073,630				
								Sheet	4
									16
									Sh.



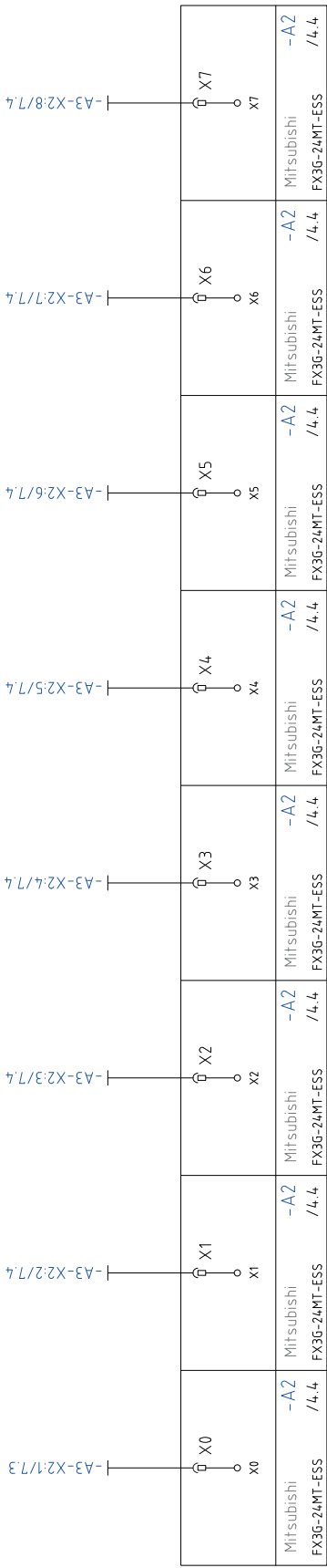

Terminal	Label	Manufacturer	Part No.	Notes
X0	-A3-X2:1/7.3	Mitsubishi	-A2 / 4.4	Handwheel A
X1	-A3-X2:2/7.4	Mitsubishi	-A2 / 4.4	Handwheel B
X2	-A3-X2:3/7.4	Mitsubishi	-A2 / 4.4	JOG -
X3	-A3-X2:4/7.4	Mitsubishi	-A2 / 4.4	LS Prg. Step
X4	-A3-X2:5/7.4	Mitsubishi	-A2 / 4.4	spare
X5	-A3-X2:6/7.4	Mitsubishi	-A2 / 4.4	JOG +
X6	-A3-X2:7/7.4	Mitsubishi	-A2 / 4.4	LS 360°
X7	-A3-X2:8/7.4	Mitsubishi	-A2 / 4.4	Emergency stop
X10	-A3-X2:9/7.4	Mitsubishi	-A2 / 4.4	Start
X11	-A3-X2:10/7.4	Mitsubishi	-A2 / 4.4	Stop
X12	-A3-X2:11/7.4	Mitsubishi	-A2 / 4.4	with/without welding
X13	-A3-X2:12/7.5	Mitsubishi	-A2 / 4.4	FRC Start
X14	-A3-X2:13/7.5	Mitsubishi	-A2 / 4.4	Handwheel Push
X15	-A3-X2:14/7.5	Mitsubishi	-A2 / 4.4	Currentflow signal

Revision	Date	Name	Date	Name
a			07.12.2015	NH
b		Drawer	12.02.11	GK
c		Assembly	21.02.11	PA
d		Project Leader		

Description		FCU-20.0	
Order	Customer	8,040,073,630	

  

= 1	
+	
Sheet	5
16	Sh.

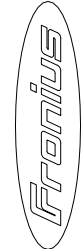

SPS inputs

act. Value      Power source B      Motor left      Motor right      Rapid gear      Ext. Start      Pneumatic      Power source A

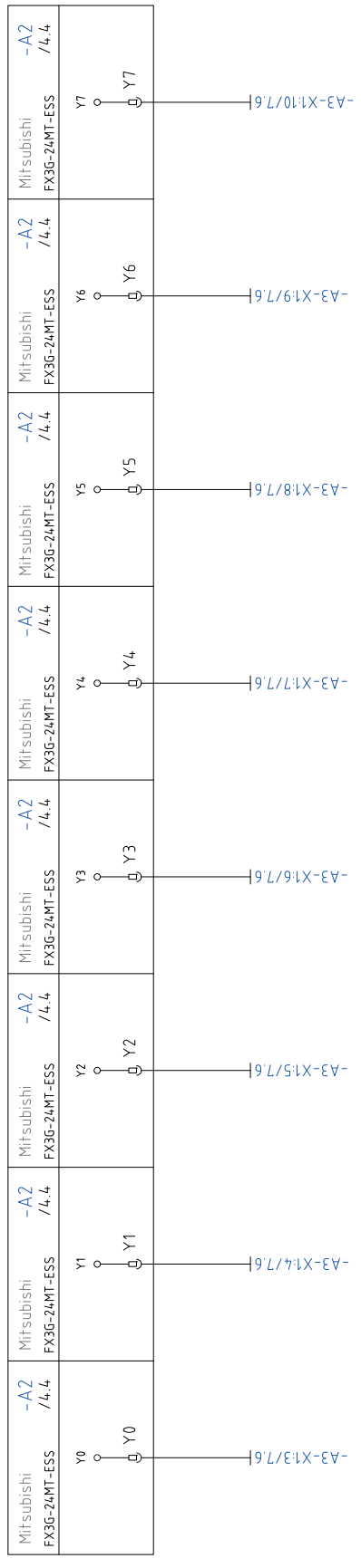

Job Job

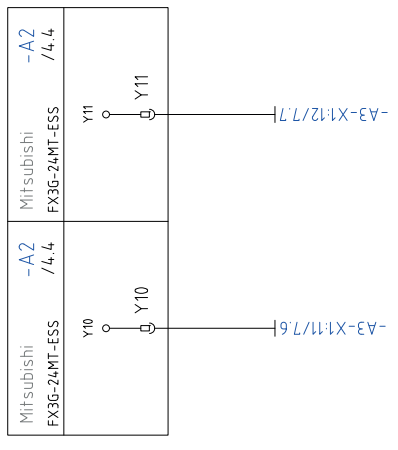

Revision	Date	Name	Date	Name	SPS Outputs		Description FCU-20.0	= 1
a			07.12.2015	NH			Order	+
b		Drawer Assembly	12.02.11	GK			Customer	
c		Project Leader	21.02.11	PA			8,040,073,630	
d								
								Sheet 6
								16
								Sh.



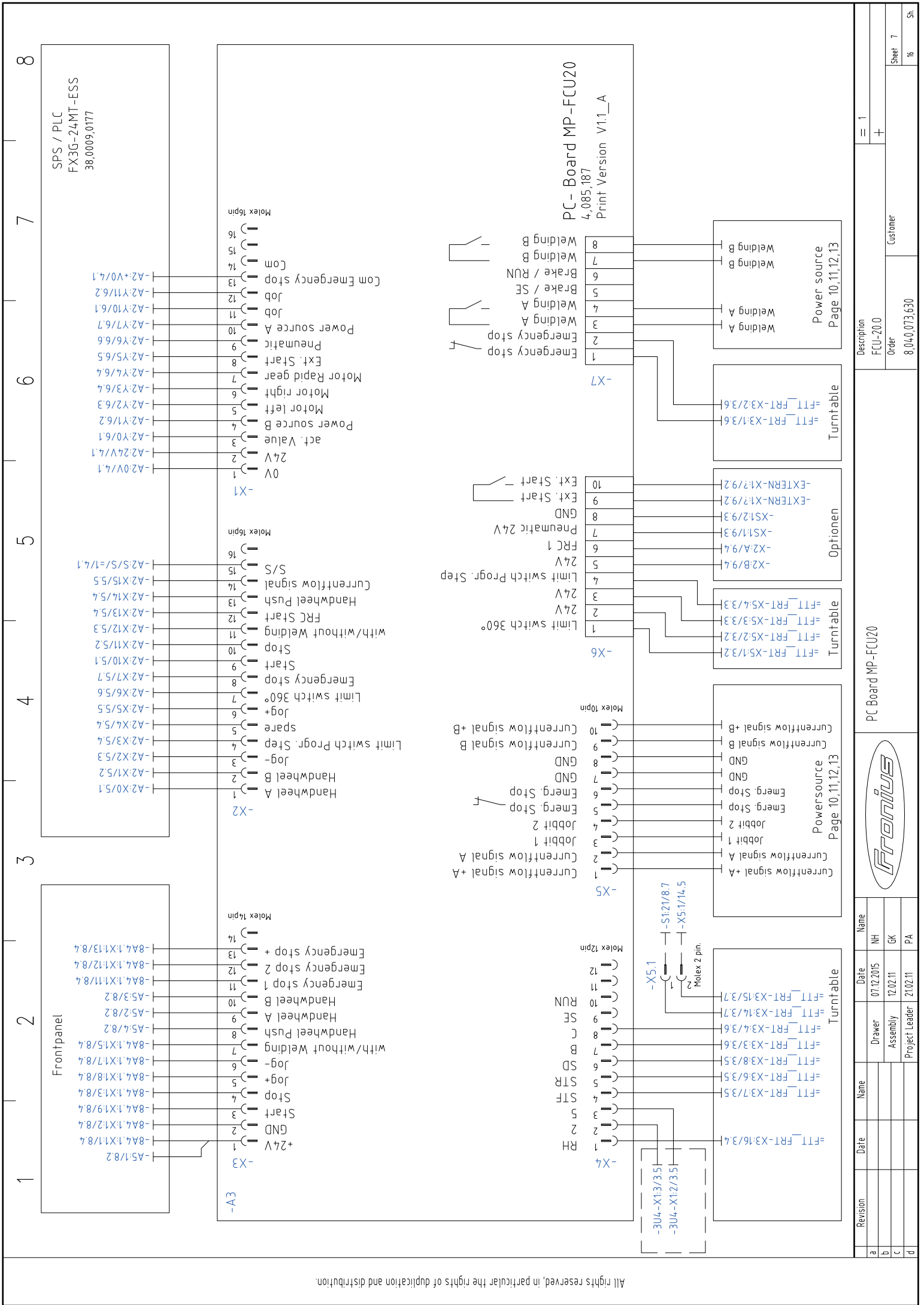

Revision	Date	Name	Date	Name
a			07.12.2015	NH
b		Drawer	12.02.11	GK
c		Assembly		
d		Project Leader	21.02.11	PA

Description		FCU-20.0	
Order		8,04,0,073,630	
Customer			

Page 10,11,12,13	
Page 10,11,12,13	Power source
Page 10,11,12,13	Welding A
Page 10,11,12,13	Welding B

Page 10,11,12,13	
Page 10,11,12,13	Power source
Page 10,11,12,13	Welding A
Page 10,11,12,13	Welding B

Page 10,11,12,13	
Page 10,11,12,13	Power source
Page 10,11,12,13	Welding A
Page 10,11,12,13	Welding B

Page 10,11,12,13	
Page 10,11,12,13	Power source
Page 10,11,12,13	Welding A
Page 10,11,12,13	Welding B

Page 10,11,12,13	
Page 10,11,12,13	Power source
Page 10,11,12,13	Welding A
Page 10,11,12,13	Welding B

  

Page 10,11,12,13	
Page 10,11,12,13	Power source
Page 10,11,12,13	Welding A
Page 10,11,12,13	Welding B

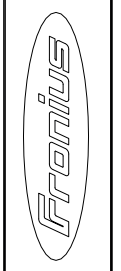

PC Board MP-FCU20

1 2 3 4 5 6 7 8

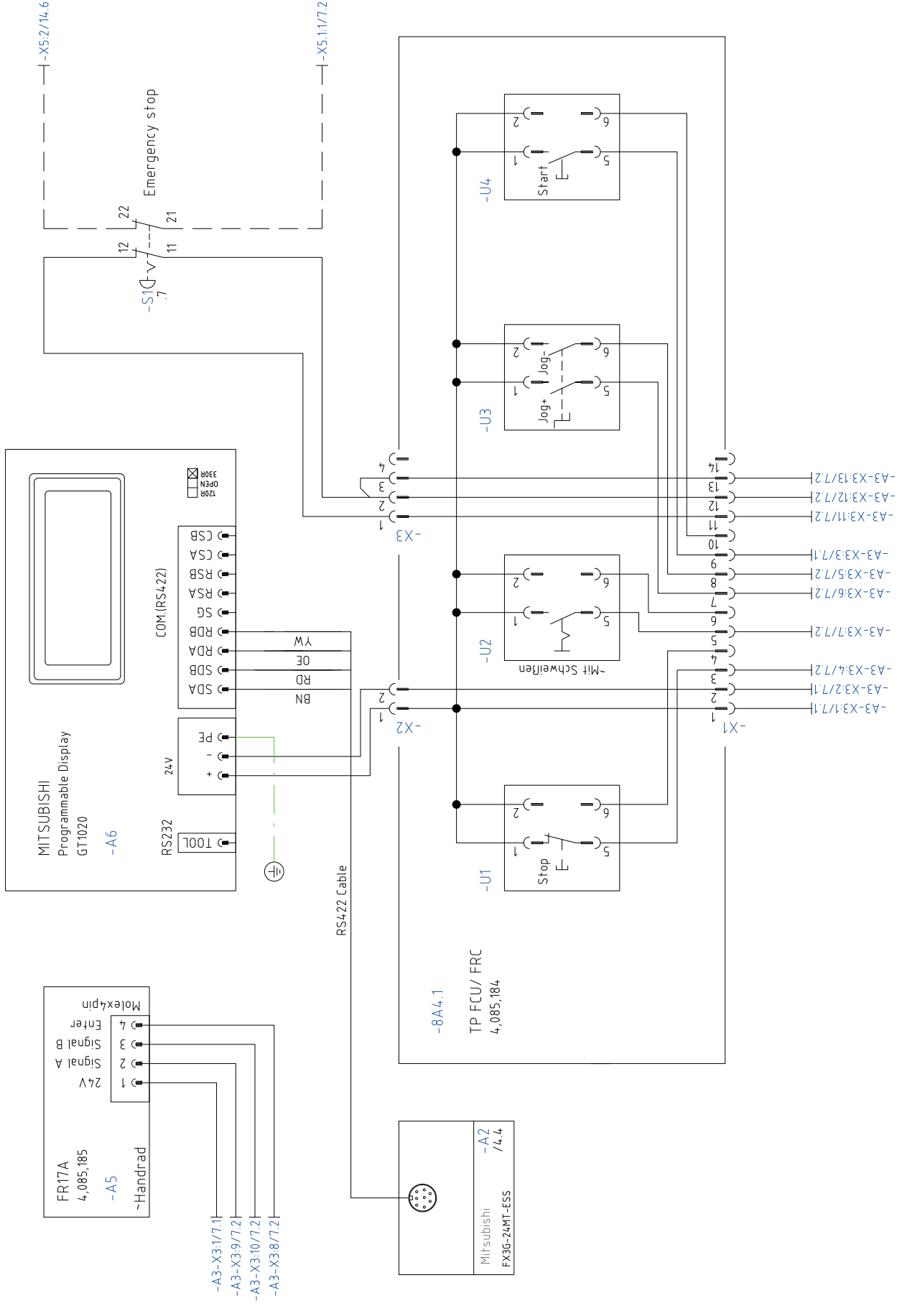

Revision	Date	Name	Date	Name	Frontpanel FCU-20	
a			07.12.2015	NH	Description FCU-20.0	
b			12.02.11	GK	Order 8,04,0,073,630	
c					Customer	
d			21.02.11	PA	Project Leader	
					Sheet	8
					16	Sh.

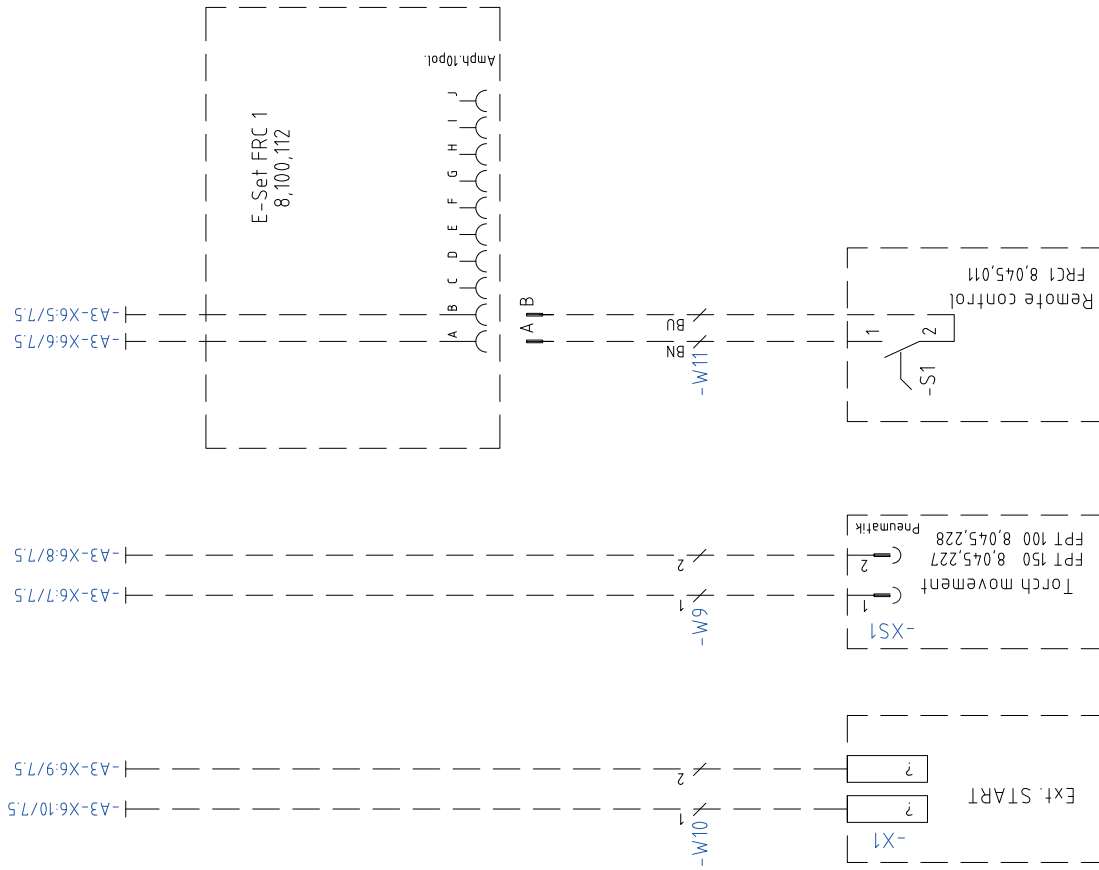

1 2 3 4 5 6 7 8

Revision	Date	Name	Date	Name	Optionen		Description	
a			07.12.2015	NH			FCU-20.0	
b		Drawer	12.02.11	GK			Order	
c		Assembly	21.02.11	PA			8,040,073,630	
d		Project Leader			Customer		Sheet 9	
							16	
							Sh.	



1 2 3 4 5 6 7 8

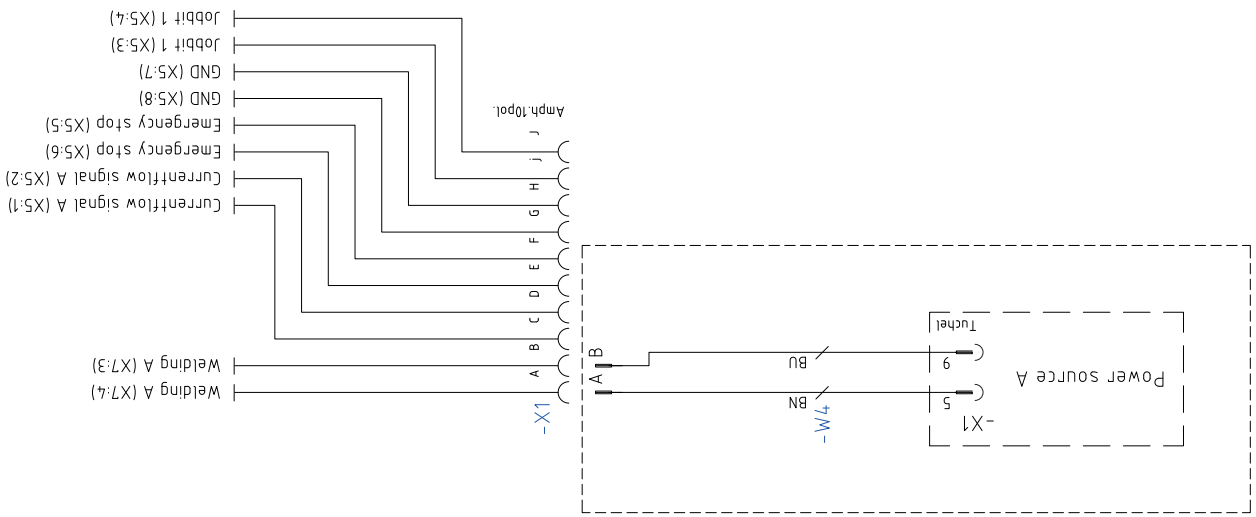

Tutchelcable 38\_0100\_0219

Revision	Date	Name	Date	Name	Description	
a			07.12.2015	NH	FCU-20.0	
b			12.02.11	GK	Order	8,040,073,630
c					Customer	
d			21.02.11	PA		

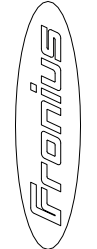

Connection Powersource Tutchel

1 2 3 4 5 6 7 8

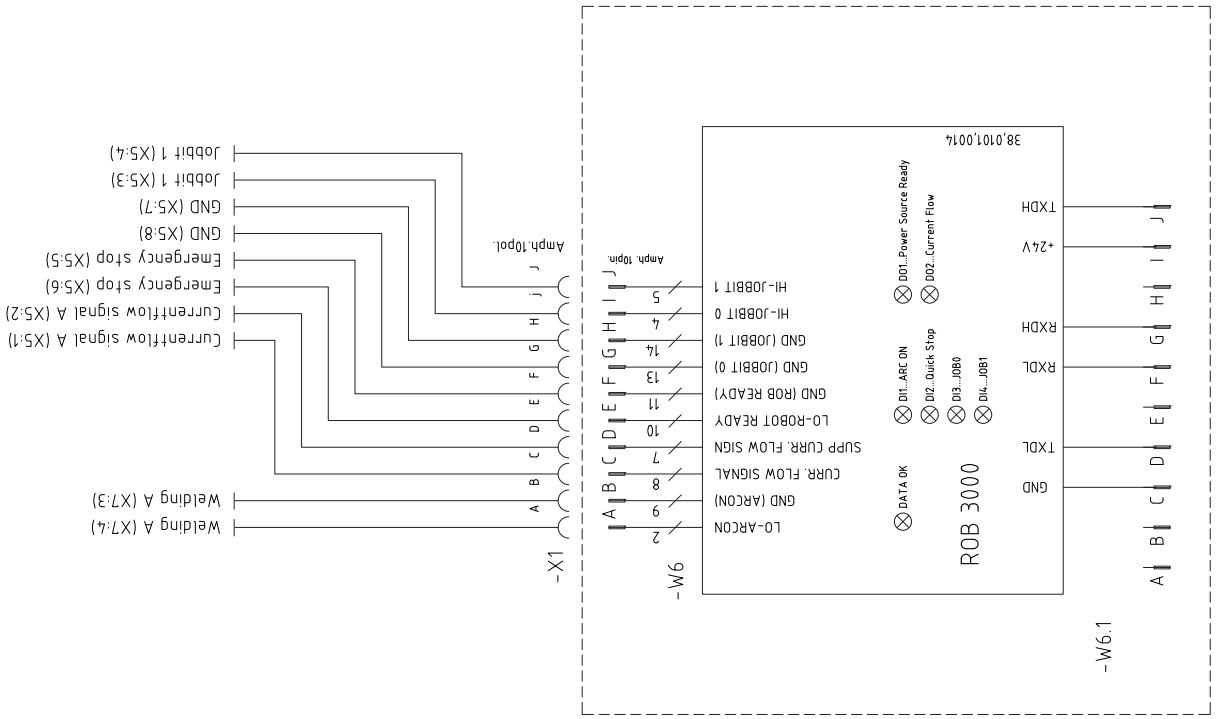

Rob 3000 38,0101,0014

Revision	Date	Name	Date	Name	Description FCU-20.0	
a	07.12.2015	NH			+	
b	12.02.11	GK			Order	Customer
c					8,04,0,073,630	
d						
					Sheet	11
					16	Sh.



Connection PowerSource ROB-3000

1 2 3 4 5 6 7 8

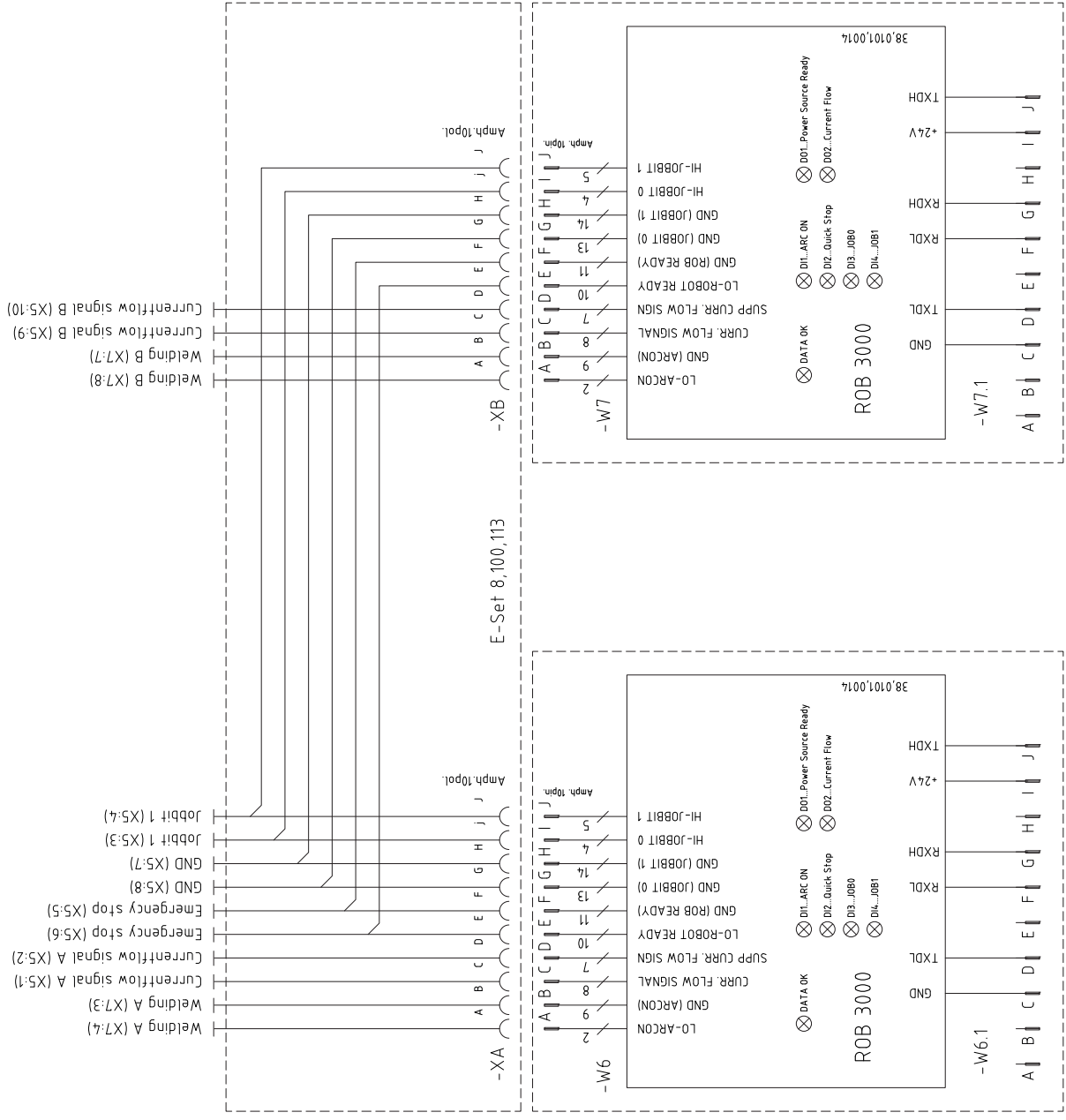

Revision	Date	Name	Date	Name	Description	
a			07.12.2015	NH	FCU-20.0	
b		Assembly	12.02.11	GK	Order	
c		Project Leader	21.02.11	PA	Customer	
d					8,04,0,073,630	

  

Description		= 1	
FCU-20.0		+	
Order		Customer	
8,04,0,073,630			
Sheet	12		
16			
Sh.			



Connection PowerSource A/B ROB-3000

1 2 3 4 5 6 7 8

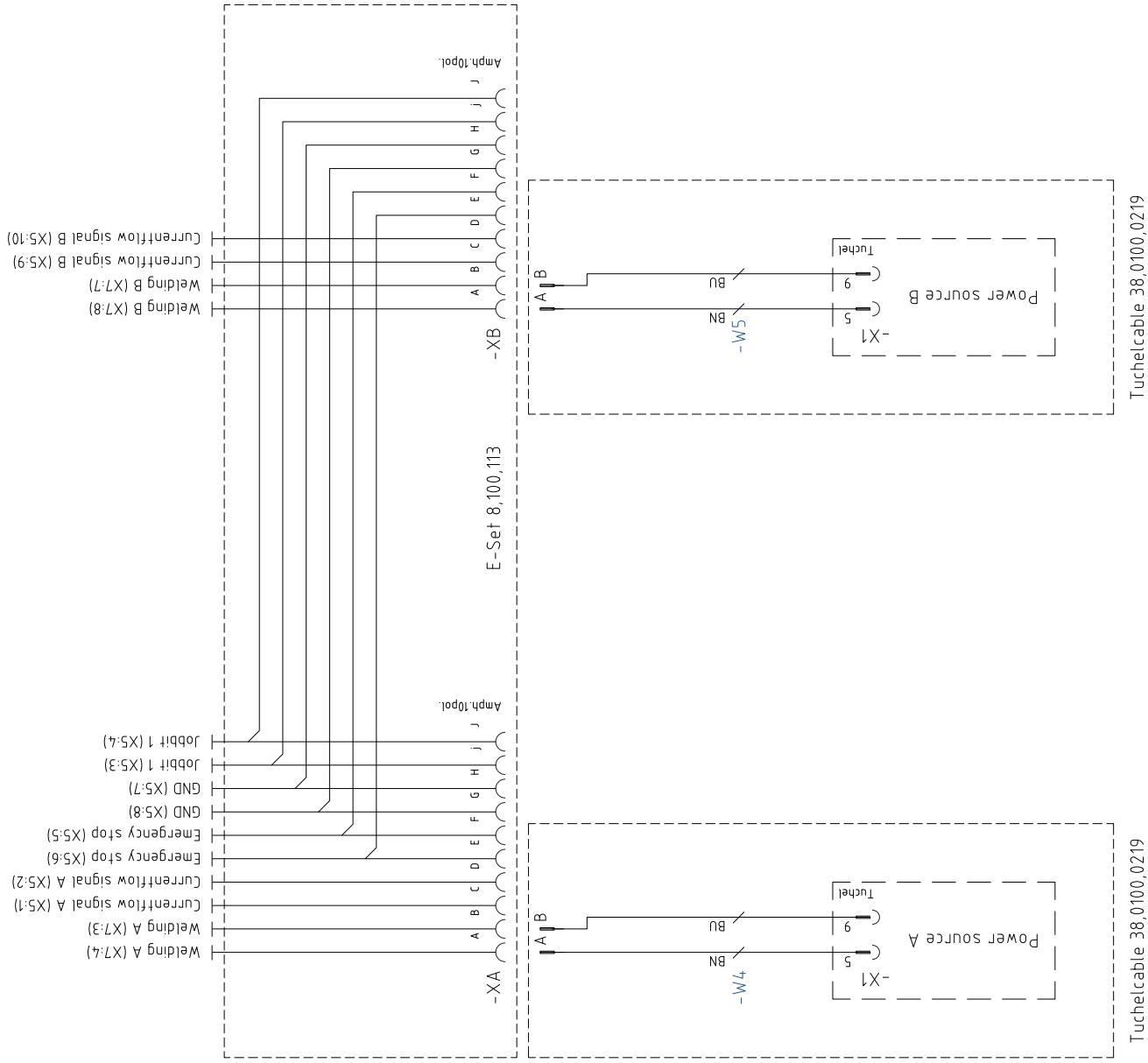

Revision	Date	Name	Date	Name	Description	
a			07.12.2015	NH	FCU-20.0	
b			12.02.11	GK	Order	
c					8,04,0,073,630	
d			21.02.11	PA	Customer	

Connection Powersource A/B Tuchel		= 1	
		+	
		Sheet 13	
		16	
		Sh.	



Tuchelcable 38,0100,0219

Tuchelcable 38,0100,0219

1 2 3 4 5 6 7 8

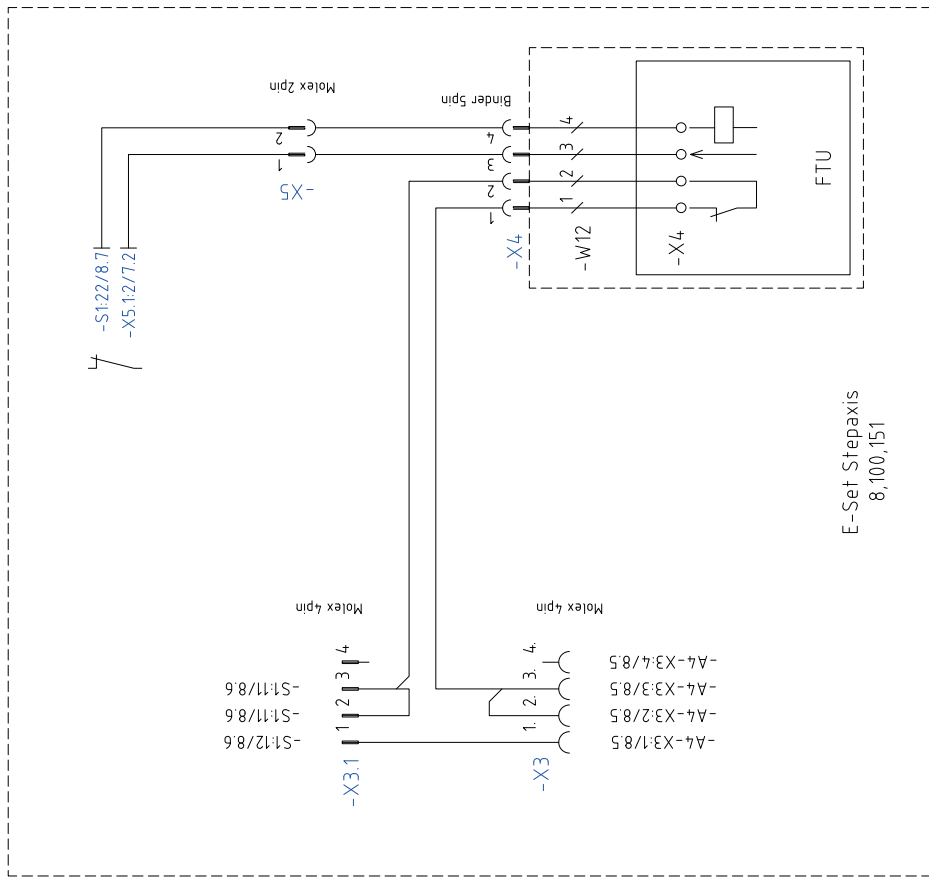

Revision	Date	Name	Date	Name	Description	Order	Customer	Sheet	It.	Sh.
a			07.12.2015	NH	FCU-20.0					
b		Drawer	12.02.11	GK						
c		Assembly								
d		Project Leader	21.02.11	PA		8,04,0,073,630				

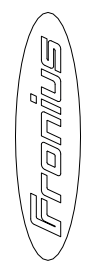

E-Set Stepaxis

8,100,151

# Hosepack FCU 20.0 / 50.0

## Cable 32cm

Han 16A  
Stift

- =1/3.4/=FTT\_FRT-X3:16 WH
- =1/3.4/=FTT\_FRT-X3:11 BN
- =1/3.5/=FTT\_FRT-X3:10 GN
- =1/3.5/=FTT\_FRT-X3:7 YE
- =1/3.5/=FTT\_FRT-X3:6 GY
- =1/3.5/=FTT\_FRT-X3:8 PK
- =1/3.6/=FTT\_FRT-X3:4 BU
- =1/3.6/=FTT\_FRT-X3:3 RD
- =1/3.7/=FTT\_FRT-X3:14 BK
- =1/3.7/=FTT\_FRT-X3:15 VT
- =1/3.6/=FTT\_FRT-X3:9 GY/PK
- =1/3.6/=FTT\_FRT-X3:1 RD/BU
- =1/3.6/=FTT\_FRT-X3:2 WH/GN
- BN/GN

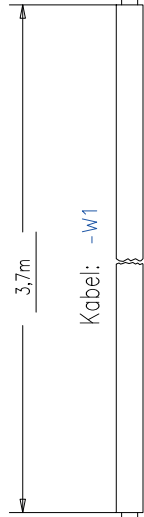

Transmission cable 14x0.34 with screen  
UNITRONIC FD-CP 14x0.34

## Cable 38cm

FCU 20.0

- =1/7.1/=1-A3-X4:1 WH
- =1/7.1/=1-A3-X4:2 BN
- =1/7.1/=1-A3-X4:3 GN
- =1/7.2/=1-A3-X4:4 YE
- =1/7.2/=1-A3-X4:5 GY
- =1/7.2/=1-A3-X4:5 PK
- =1/7.2/=1-A3-X4:6 BU
- =1/7.2/=1-A3-X4:8 RD
- =1/7.2/=1-A3-X4:7 BK
- =1/7.2/=1-X5:1:1 VT
- =1/7.2/=1-X5:1:2 GY/PK
- =1/7.6/=1-A3-X7:1 RD/BU
- =1/7.6/=1-A3-X7:2 WH/GN
- BN/GN

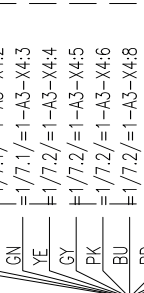

Control cable 5x0.75  
Ölflex Classic 110 560.75

FCU 50.0

- A1-X10:1
- A1-X10:3
- A1-X10:4
- A1-X10:6
- A1-X10:5
- A1-X10:7
- A1-X10:10
- A1-X10:9
- A1-X10:2
- K1:12
- K1:11

## Kabel 32cm

Han 6A  
Buchse

- =1/3.2/=FTT\_FRT-X5:1 1
- =1/3.2/=FTT\_FRT-X5:2 2
- =1/3.3/=FTT\_FRT-X5:3 3
- =1/3.3/=FTT\_FRT-X5:4 4
- GNVE

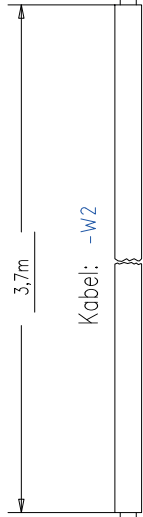

- =1/7.4/=1-A3-X6:1 1
- =1/7.5/=1-A3-X6:2 2
- =1/7.5/=1-A3-X6:3 3
- =1/7.5/=1-A3-X6:4 4
- GNVE

- A1-X12:1
- A1-X12:2
- N.C
- N.C

Hose 3m 22x1,5 SW

Revision	Date	Name	Date	Name
a			07.12.2015	NH
b		Drawer Assembly	12.02.11	GK
c		Project Leader	21.02.11	PA
d				

Hosepack 38,0100,0237		Description FCU-20.0	
Order 8,04,0,073,630		Customer	
		= 1	
		+	
		Sheet 15	
		16	
		Sh.	



1 2 3 4 5 6 7 8

Revision	Date	Name	Date	Name	Description	Order	Customer	Sheet	16	Sh.
a			07.12.2015	NH	FCU-20.0					
b										
c										
d										
						8,040,073,630				









**FRONIUS INTERNATIONAL GMBH**

**TechSupport Automation**

Froniusplatz 1, A-4600 Wels, Austria

E-Mail: [support.automation@fronius.com](mailto:support.automation@fronius.com)

[www.fronius.com](http://www.fronius.com)

**[www.fronius.com/addresses](http://www.fronius.com/addresses)**

Under <http://www.fronius.com/addresses> you will find all addresses  
of our Sales & service partners and Locations.

